



US008282234B2

(12) **United States Patent**
VanDerWoude et al.

(10) **Patent No.:** **US 8,282,234 B2**

(45) **Date of Patent:** **Oct. 9, 2012**

(54) **MEDICAL/SURGICAL PERSONAL PROTECTION SYSTEM INCLUDING A LIGHT ASSEMBLY ARRANGED SO THAT HEAT GENERATED BY THE ASSEMBLY IS EXHAUSTED AWAY FROM THE ASSEMBLY**

(75) Inventors: **Brian VanDerWoude**, Portage, MI (US); **Marshall Proulx**, Kalamazoo, MI (US); **Jacob C. Foor**, Mattawan, MI (US); **Douglas Campbell**, Kalamazoo, MI (US); **David H. Grulke**, Battle Creek, MI (US)

(73) Assignee: **Stryker Corporation**, Kalamazoo, MI (US)

(*) Notice: Subject to any disclaimer, the term of this patent is extended or adjusted under 35 U.S.C. 154(b) by 280 days.

(21) Appl. No.: **12/813,084**

(22) Filed: **Jun. 10, 2010**

(65) **Prior Publication Data**

US 2011/0004979 A1 Jan. 13, 2011

Related U.S. Application Data

(62) Division of application No. 11/485,783, filed on Jul. 13, 2006, now Pat. No. 7,735,156.

(60) Provisional application No. 60/699,166, filed on Jul. 14, 2005.

(51) **Int. Cl.**
F21V 21/084 (2006.01)

(52) **U.S. Cl.** **362/106**; 362/105; 128/200.24; 128/200.25; 128/200.26; 2/428; 2/410

(58) **Field of Classification Search** 362/105, 362/106; 2/410, 421, 428; 128/200.24, 200.25, 128/200.26

See application file for complete search history.

(56) **References Cited**

U.S. PATENT DOCUMENTS

4,280,491	A	7/1981	Berg et al.	
4,901,716	A	2/1990	Stackhouse et al.	
5,009,225	A	4/1991	Vrabel	
5,054,480	A	10/1991	Bare et al.	
6,393,617	B1	5/2002	Paris et al.	
6,481,019	B2	11/2002	Diaz et al.	
6,711,748	B2	3/2004	Paris et al.	
6,990,691	B2	1/2006	Klotz et al.	
7,200,873	B2	4/2007	Klotz et al.	
7,534,005	B1 *	5/2009	Buckman	362/105
2001/0032348	A1	10/2001	Diaz et al.	

(Continued)

FOREIGN PATENT DOCUMENTS

EP 0 199 449 A2 10/1986

(Continued)

OTHER PUBLICATIONS

EPO, International Search Report for PCT App. No. PCT/US2006/027214, Feb. 2007.

(Continued)

Primary Examiner — Evan Dzierzynski

(57) **ABSTRACT**

A personal protection system for providing a sterile barrier around medical/surgical personnel. The system includes a helmet over which a hood or a toga suspended. Integral with the helmet is a ventilation fan. The helmet also includes a light assembly for illuminating the surgical field. The helmet includes a front nozzle from which air from the ventilation fan is discharged. The light assembly is mounted to the helmet and is located below the front nozzle. Air discharged from the front nozzle blows heat generated by the light assembly away from the light assembly. In some versions of the invention, the light assembly includes a control arm connected to the light assembly for pivoting the light assembly.

20 Claims, 47 Drawing Sheets

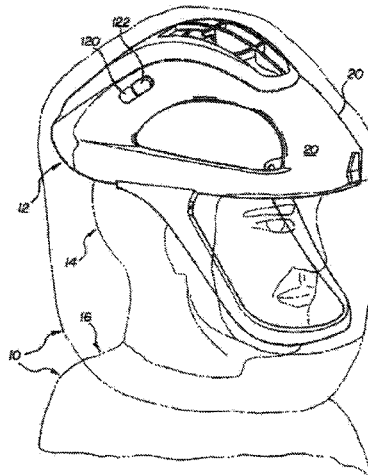

U.S. PATENT DOCUMENTS

2003/0083112 A1 5/2003 Fukuda
2005/0010992 A1 1/2005 Klotz et al.
2005/0117327 A1 6/2005 Gupta
2006/0133069 A1 6/2006 Clupper et al.
2007/0050898 A1* 3/2007 Larson et al. 2/456

FOREIGN PATENT DOCUMENTS

EP 0 338 714 A2 10/1989
EP 0 465 971 A2 1/1992

OTHER PUBLICATIONS

EPO, ISA Written Opinion for PCT App. No. PCT/US2006/027214,
Feb. 2007.
U.S. Appl. No. 60/664,900, filed Mar. 24, 2005.
Stryker Instruments, T-4 Fiber Optic Surgical Helmet Assembly,
Eng. Drawings, May 2000, Kalamazoo, MI.
Stryker Instruments, T4 Personal Protection System, T4 Fiber Optic
Surgical Helmet, Instructions for Use, Jun. 2004, Kalamazoo, MI.

* cited by examiner

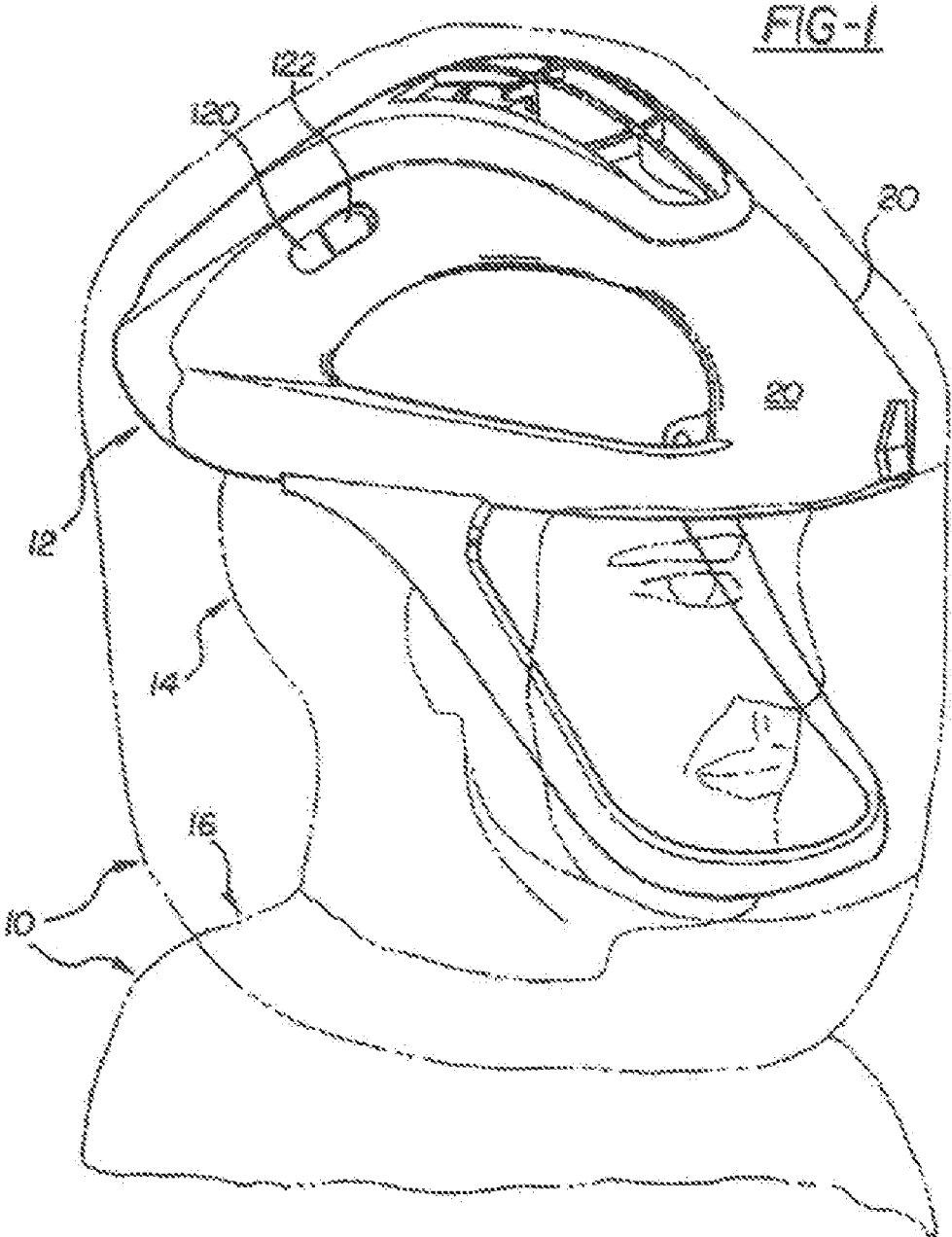

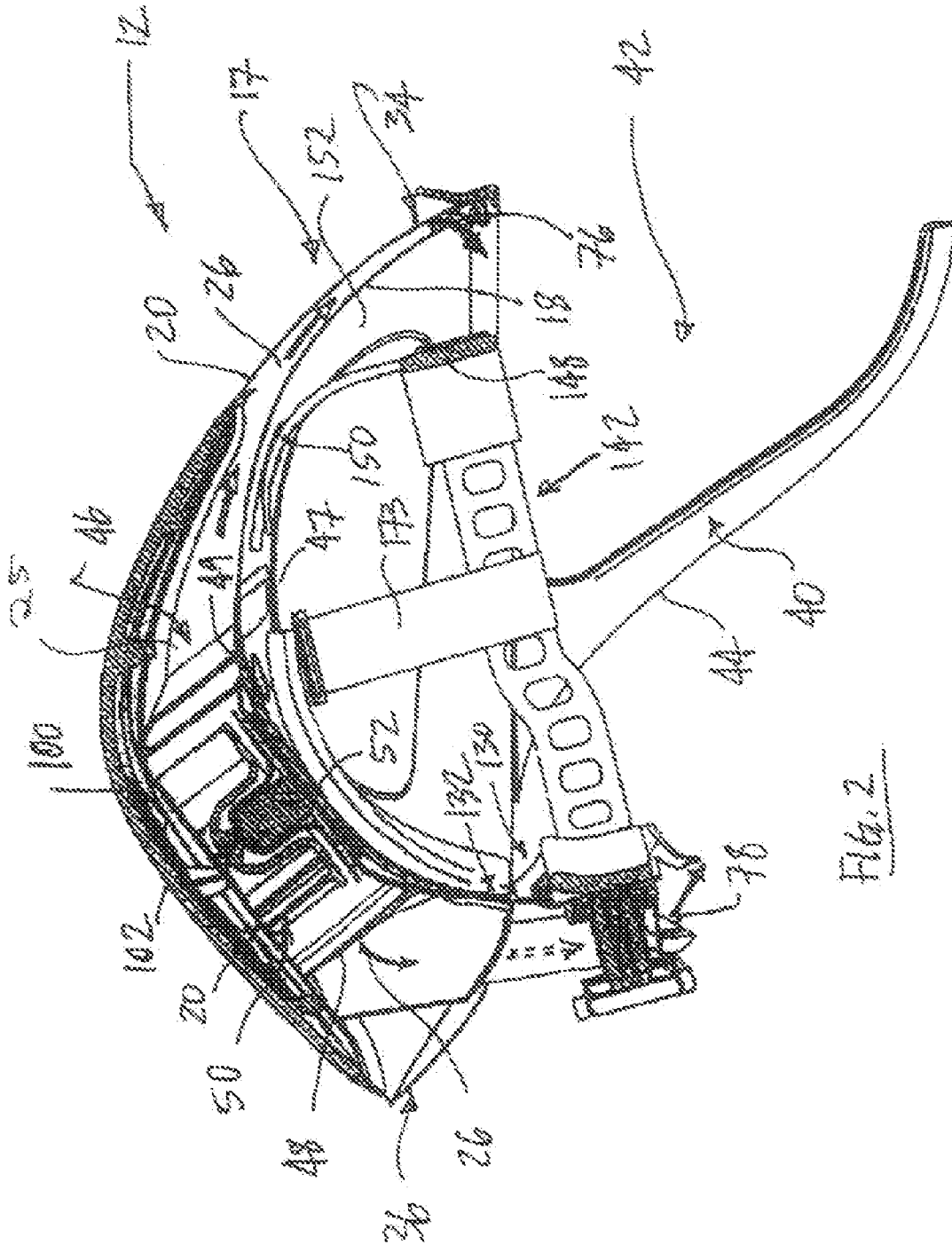

Fig. 2

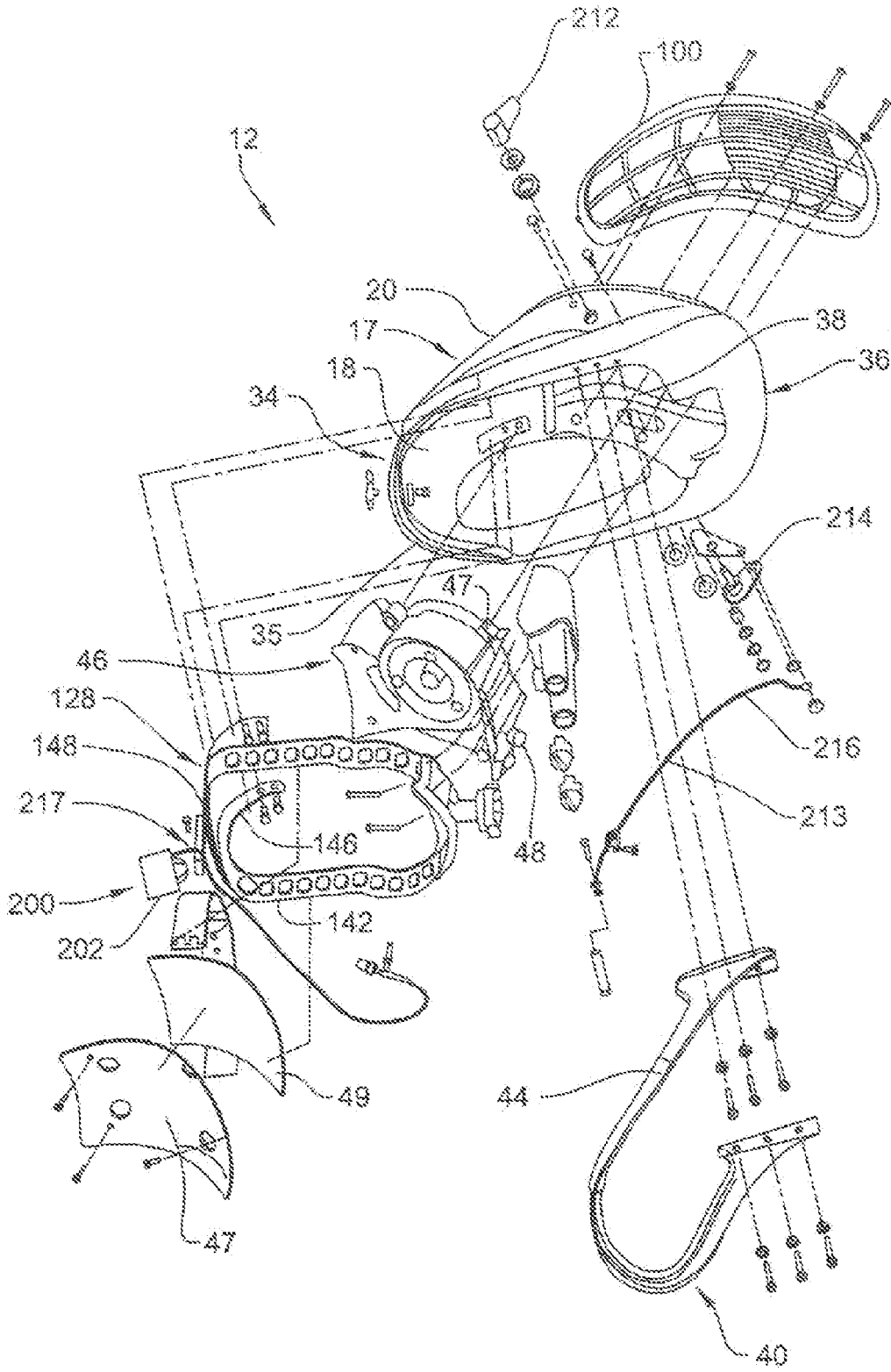

FIG. 3

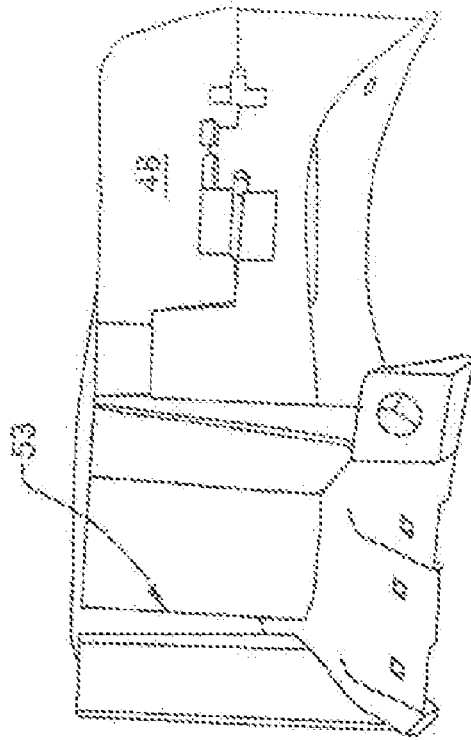

FIG. 3B

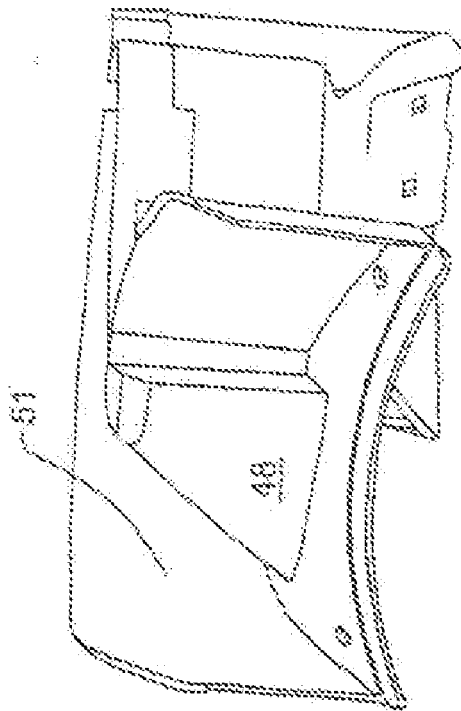

FIG. 3A

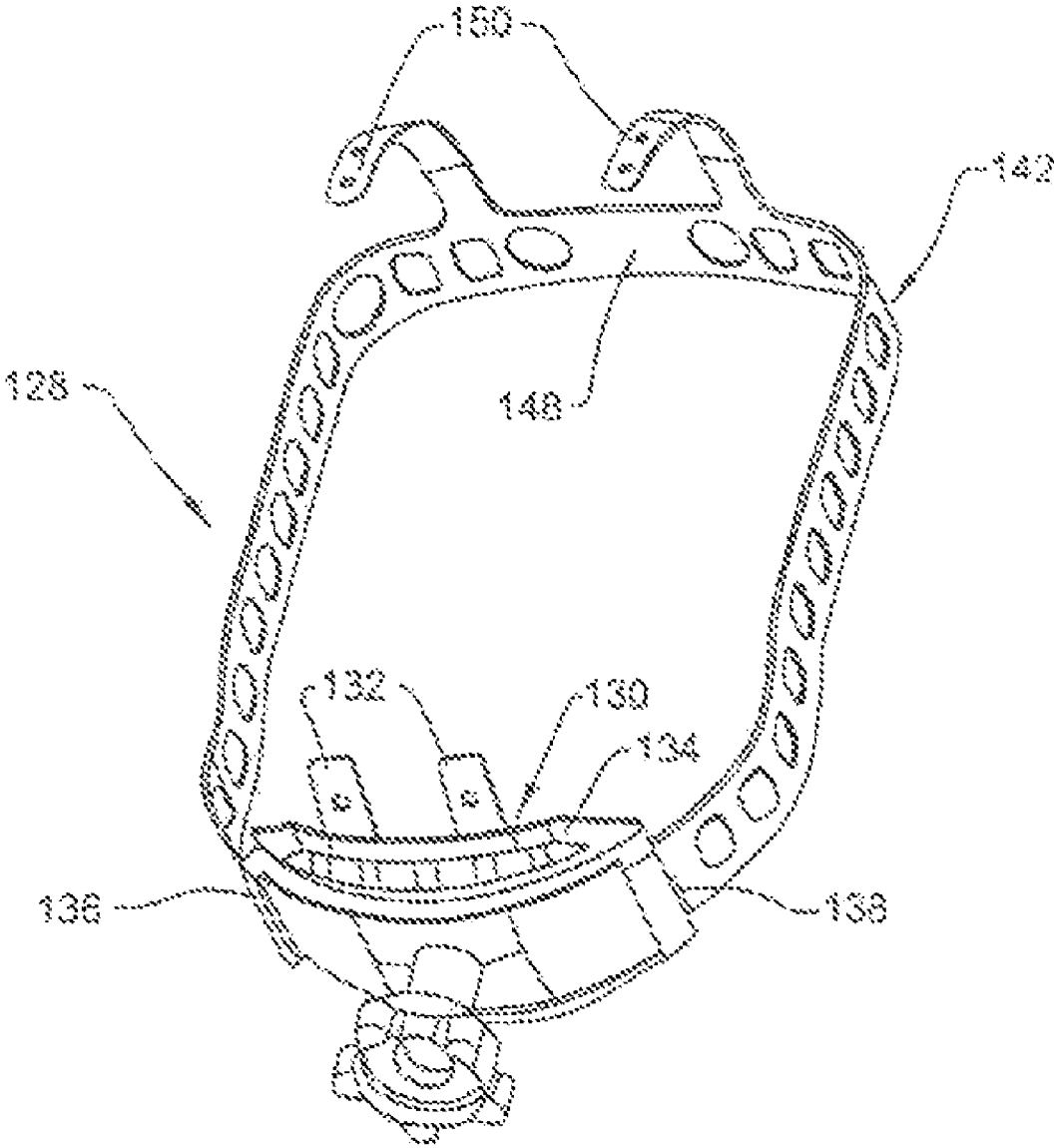

FIG. 4

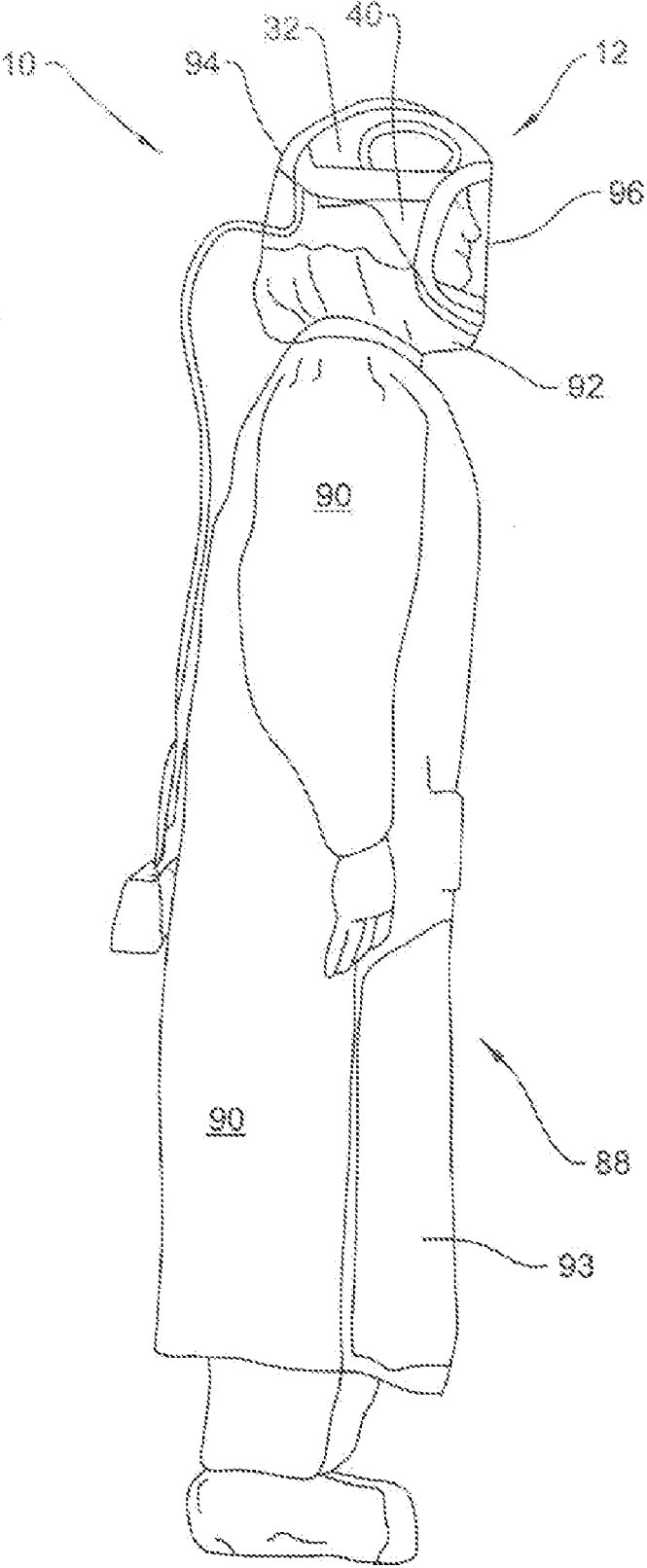
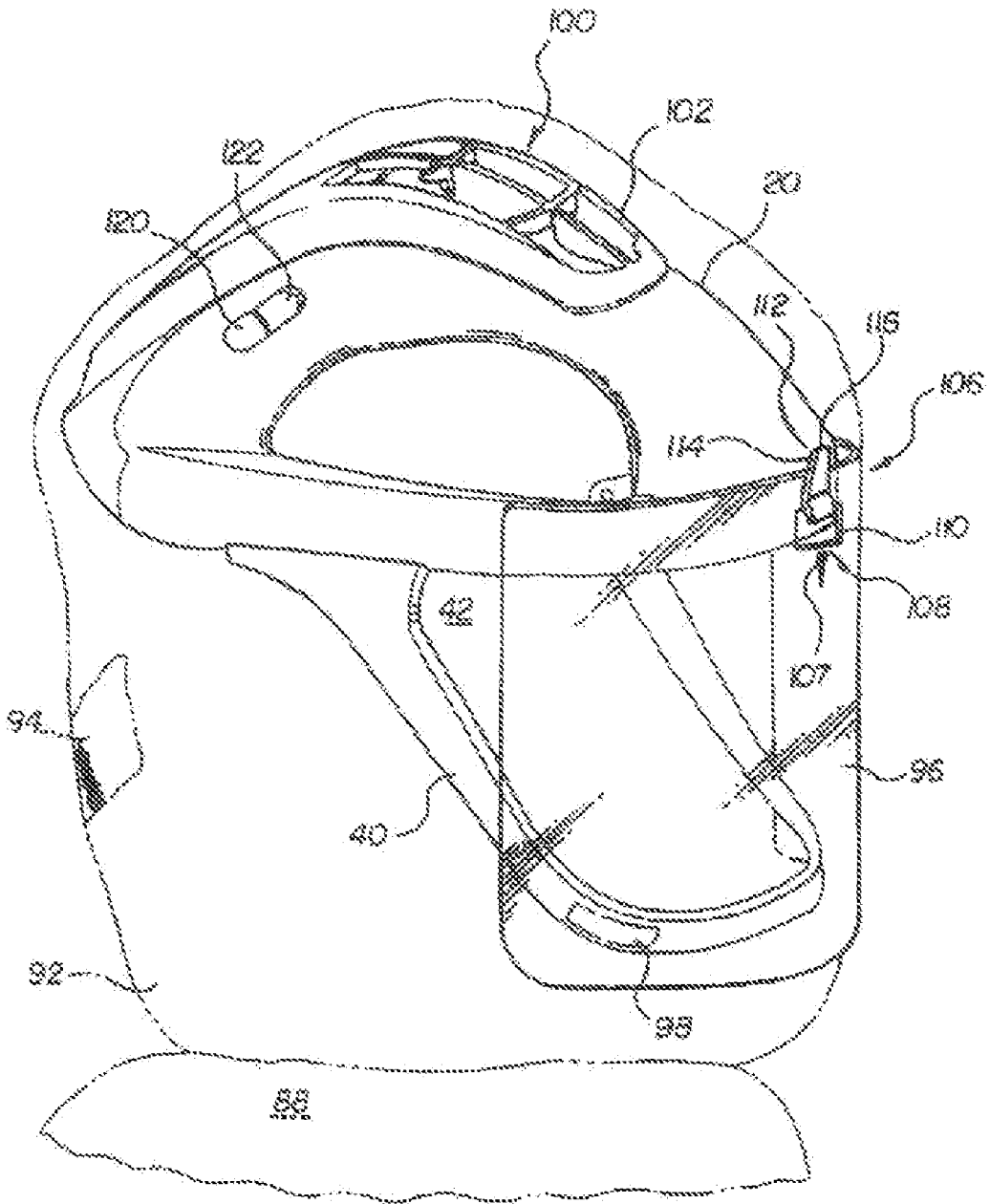

FIG. 5

FIG. 6



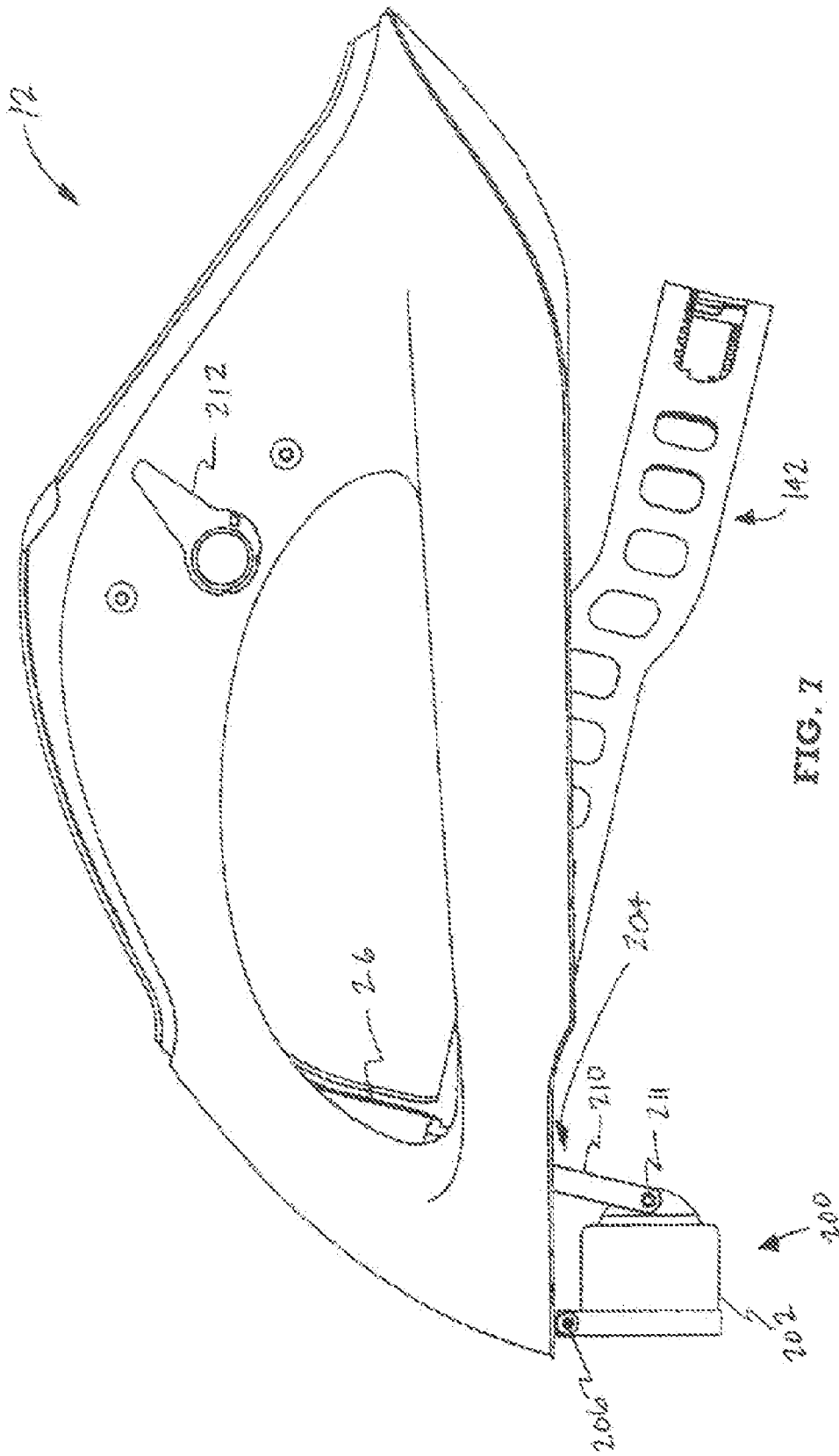

FIG. 7

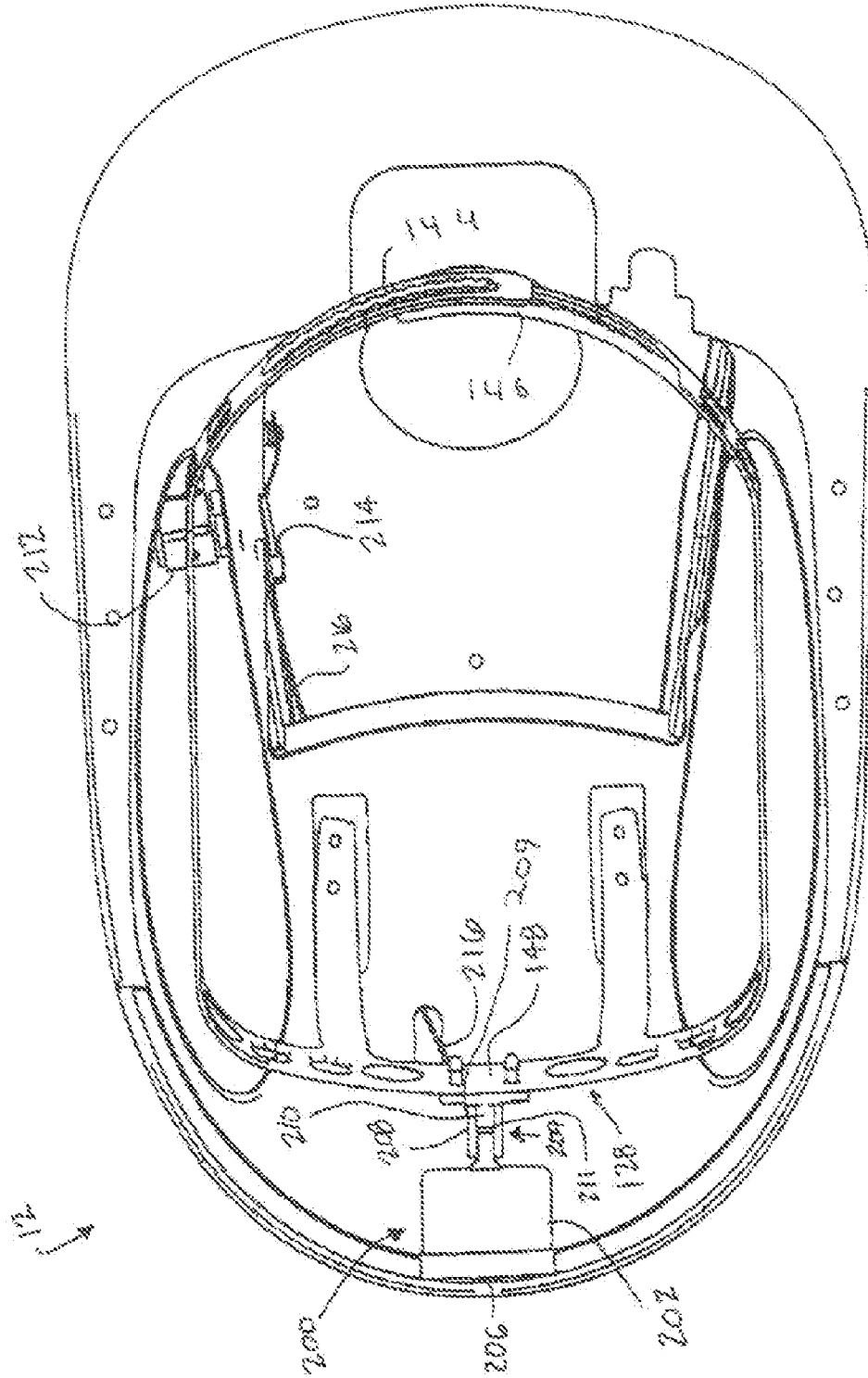
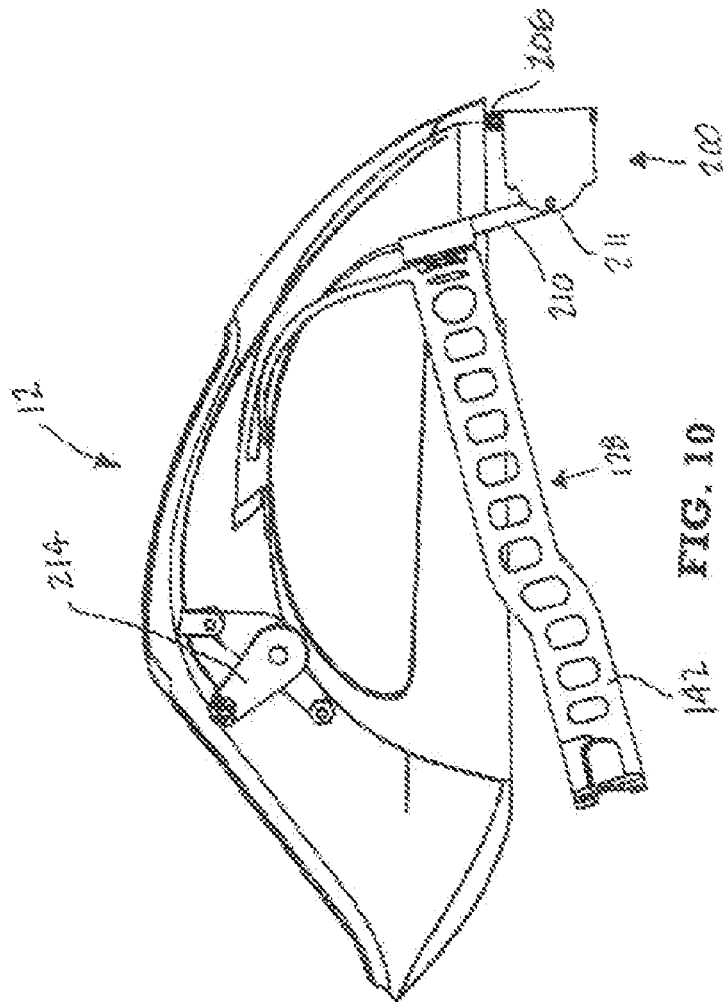
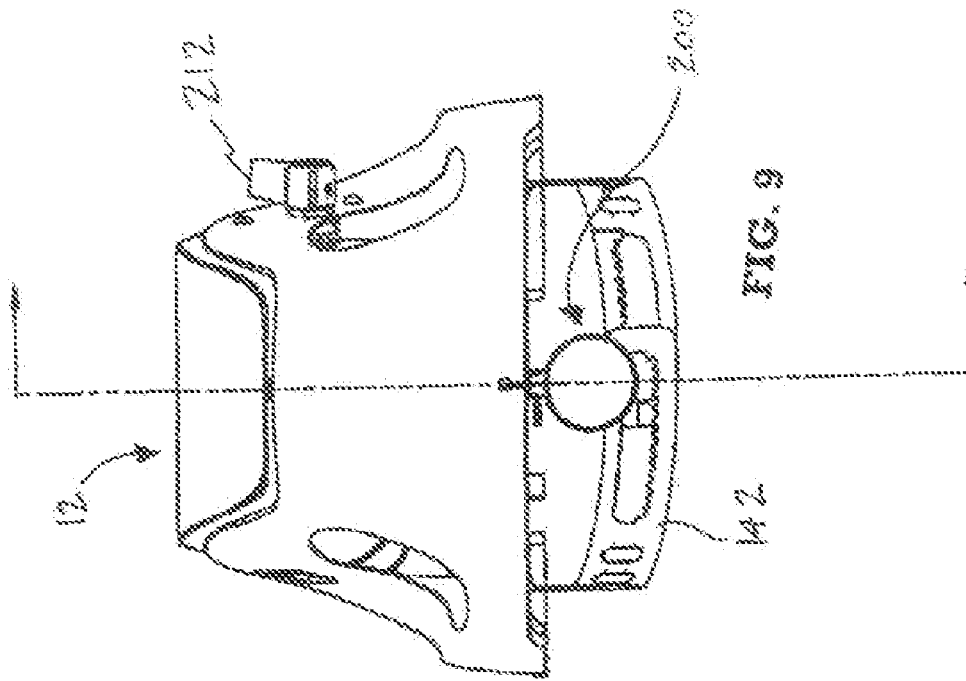

FIG. 8.



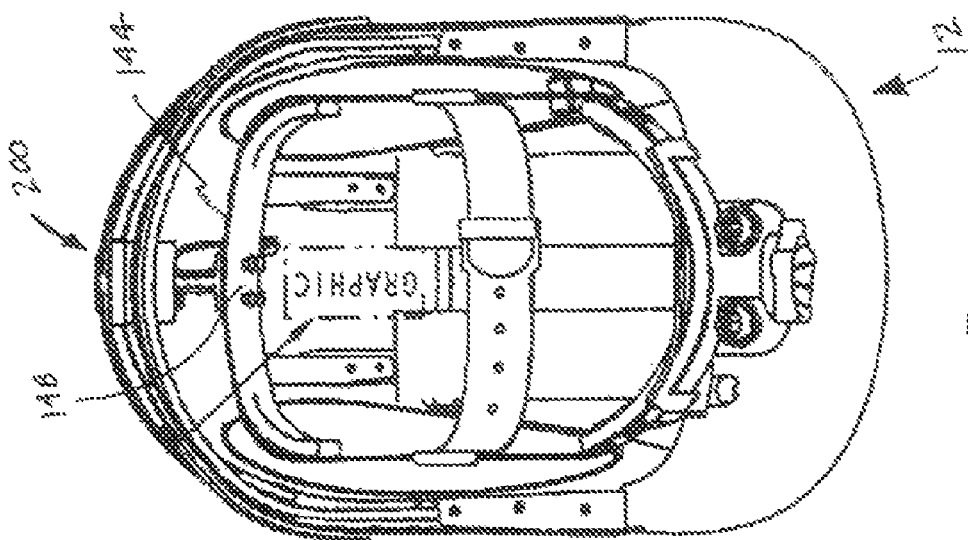

FIG. 11

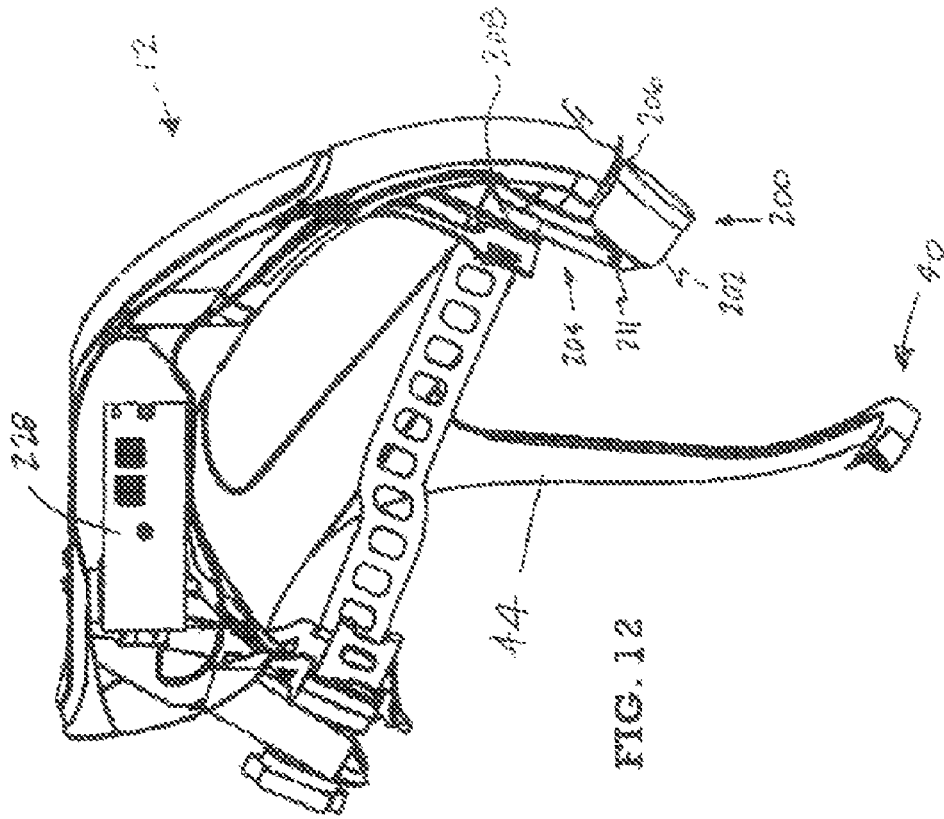

FIG. 12

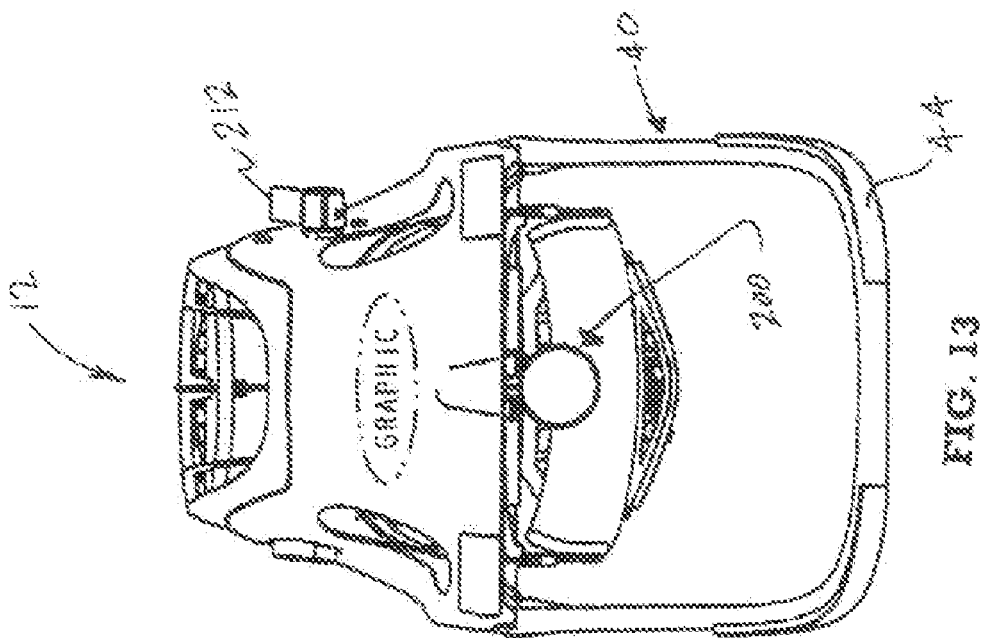

FIG. 13

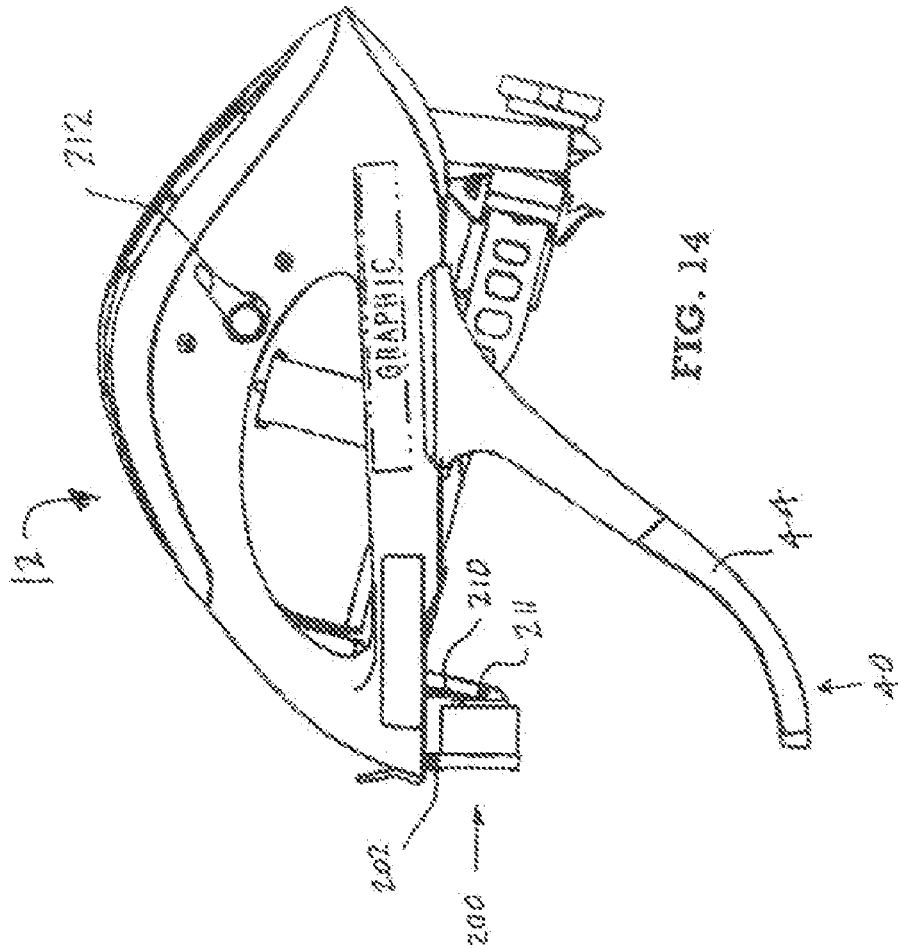

FIG. 14

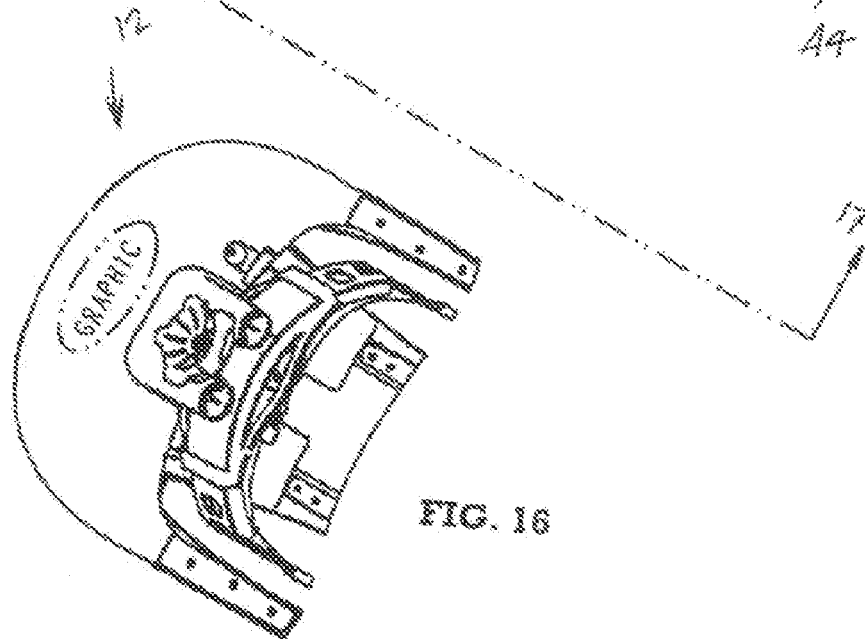
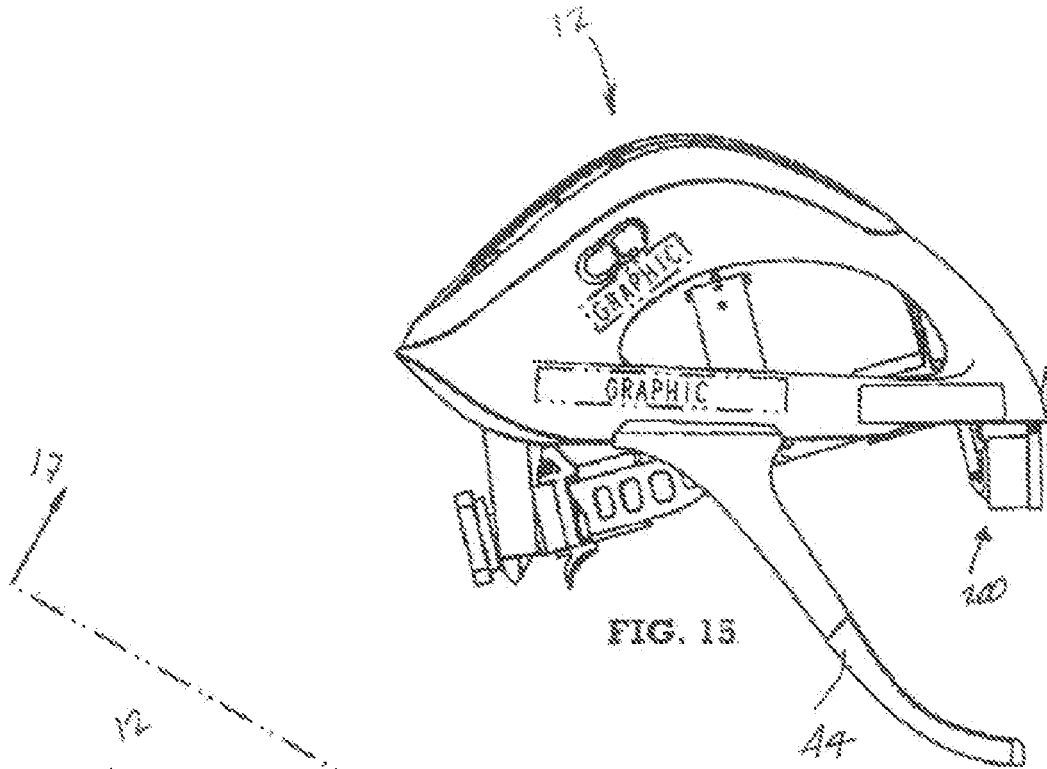
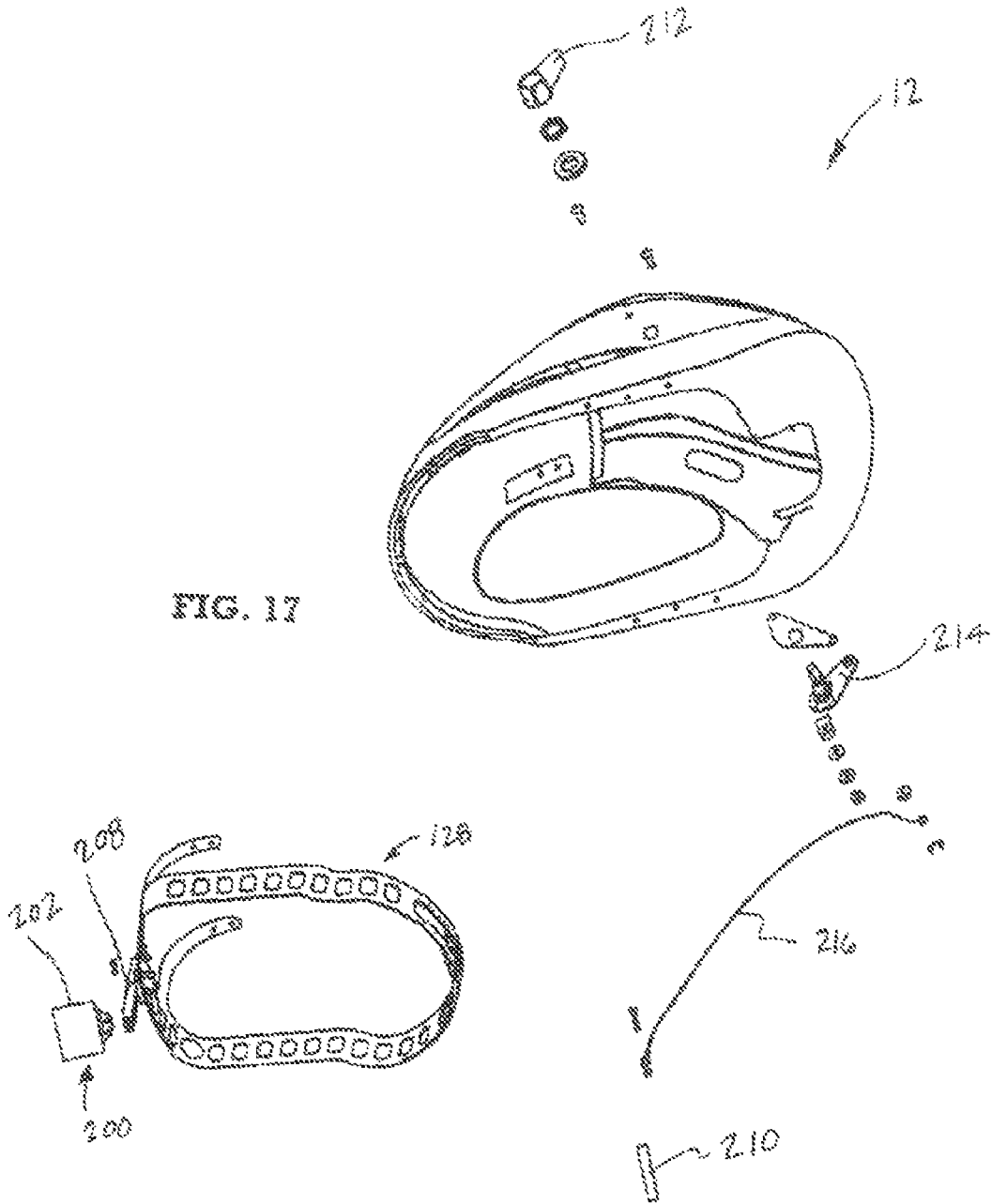
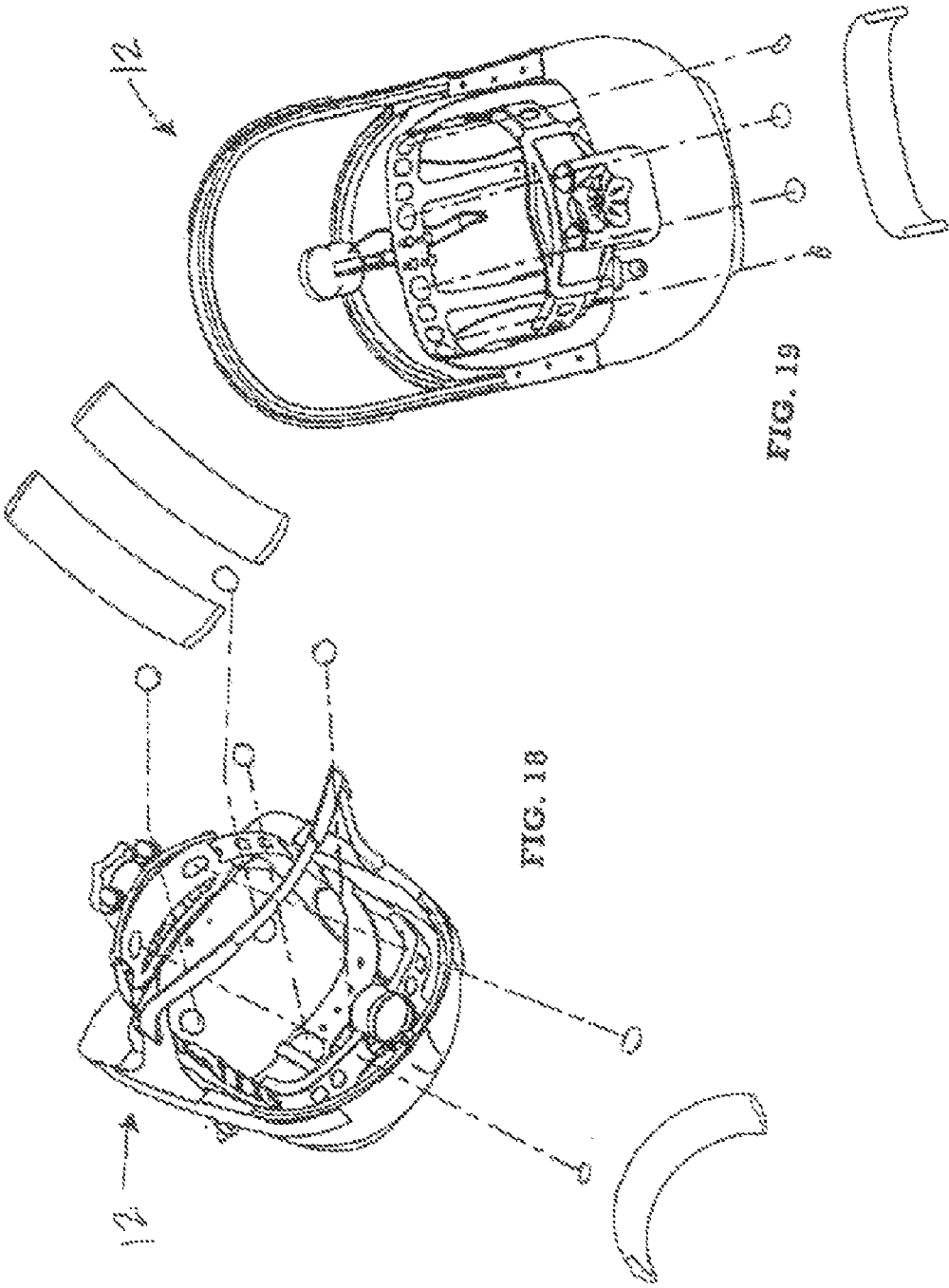

FIG. 17





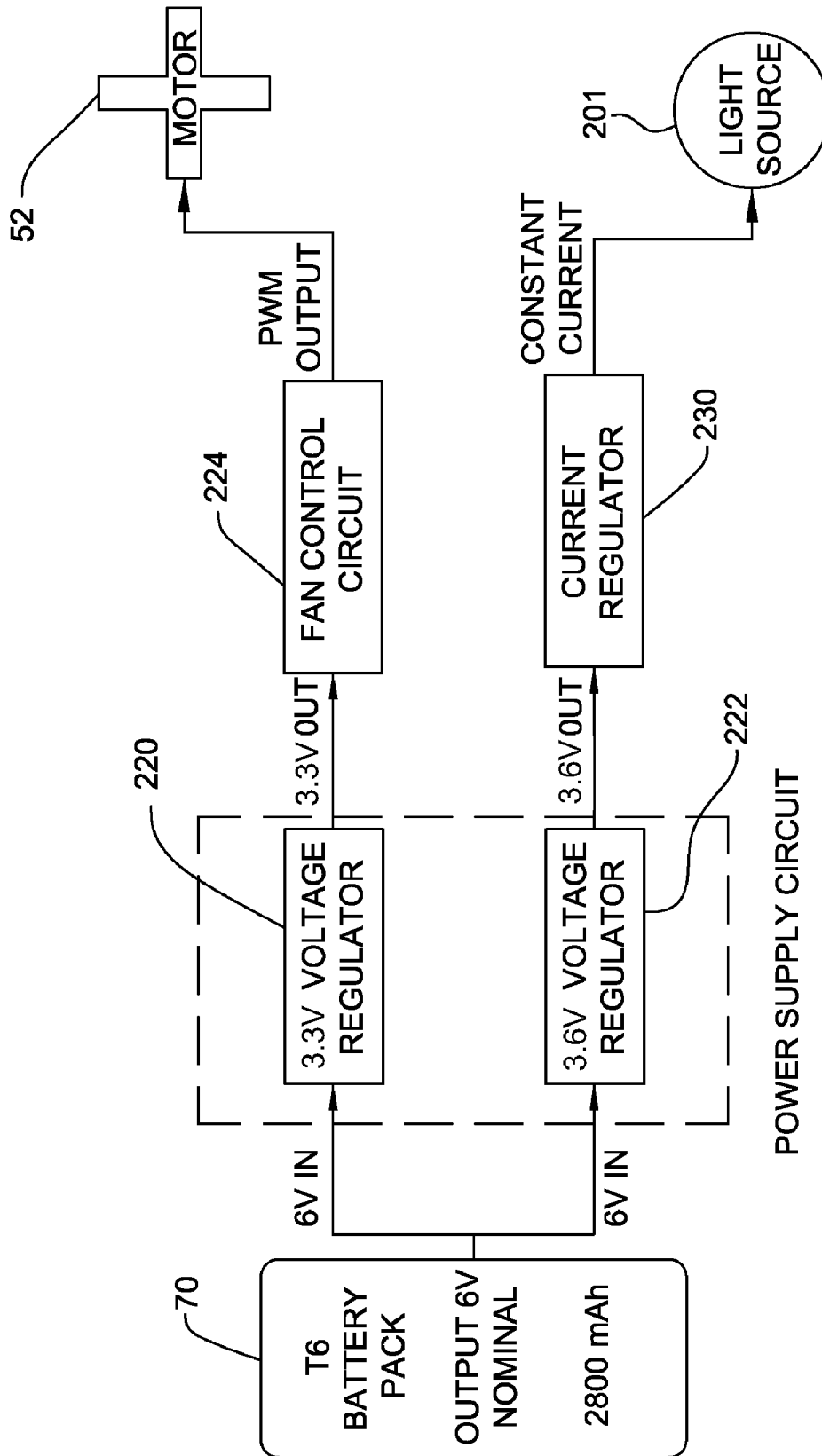

FIG. 20

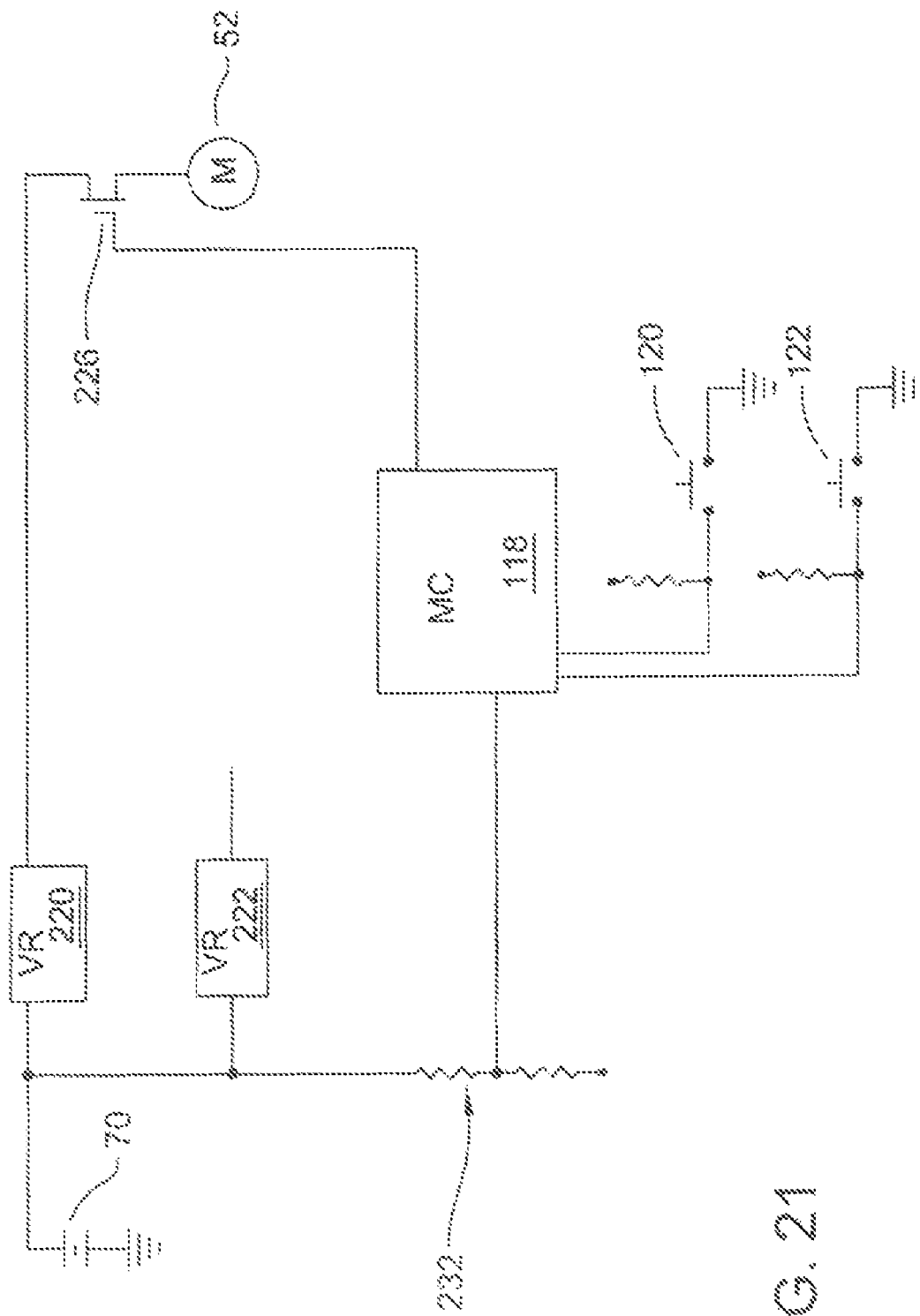

FIG. 21

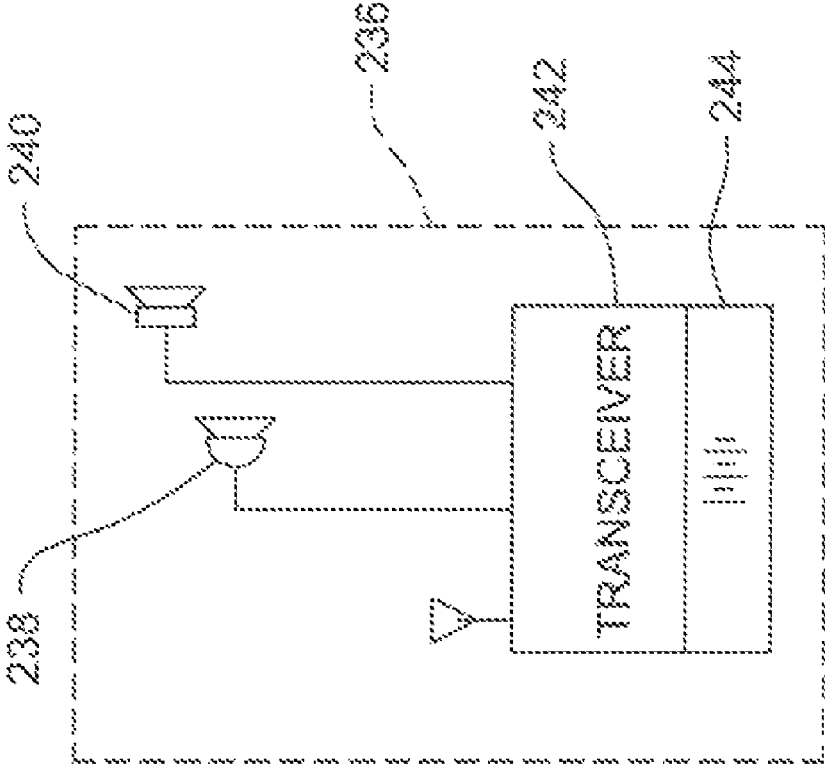
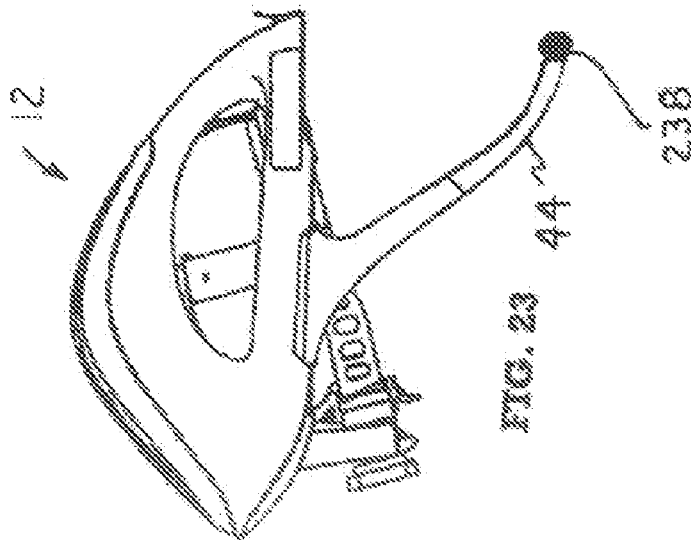
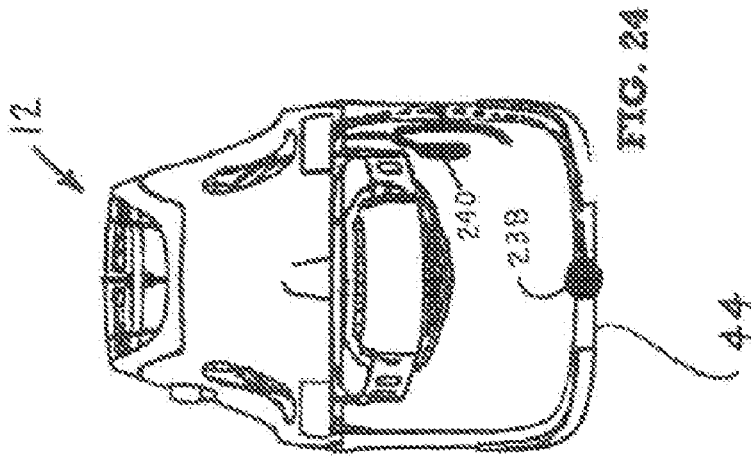
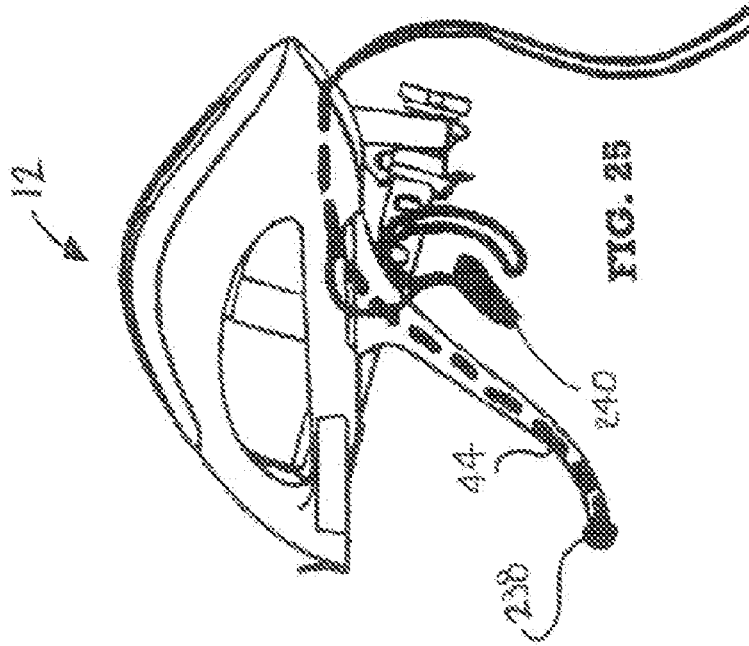

FIG. 22



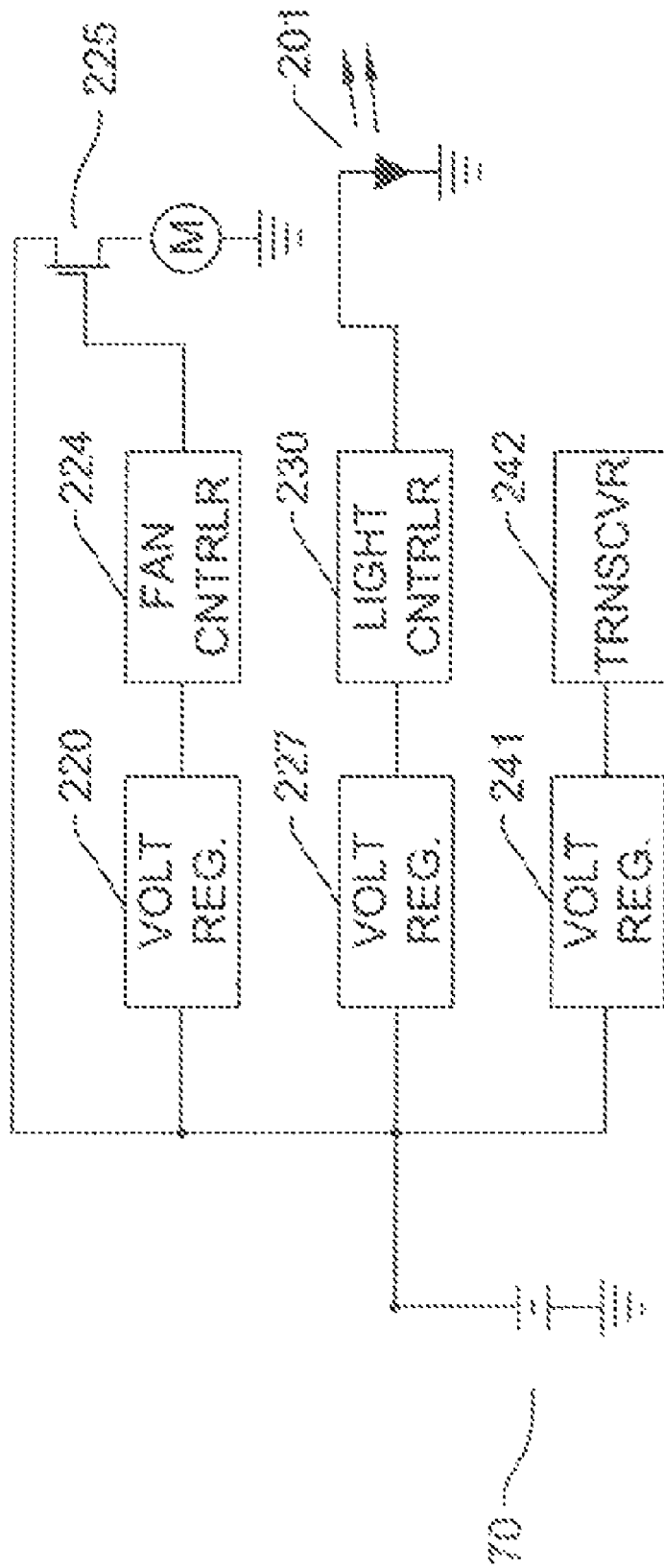

FIG. 26

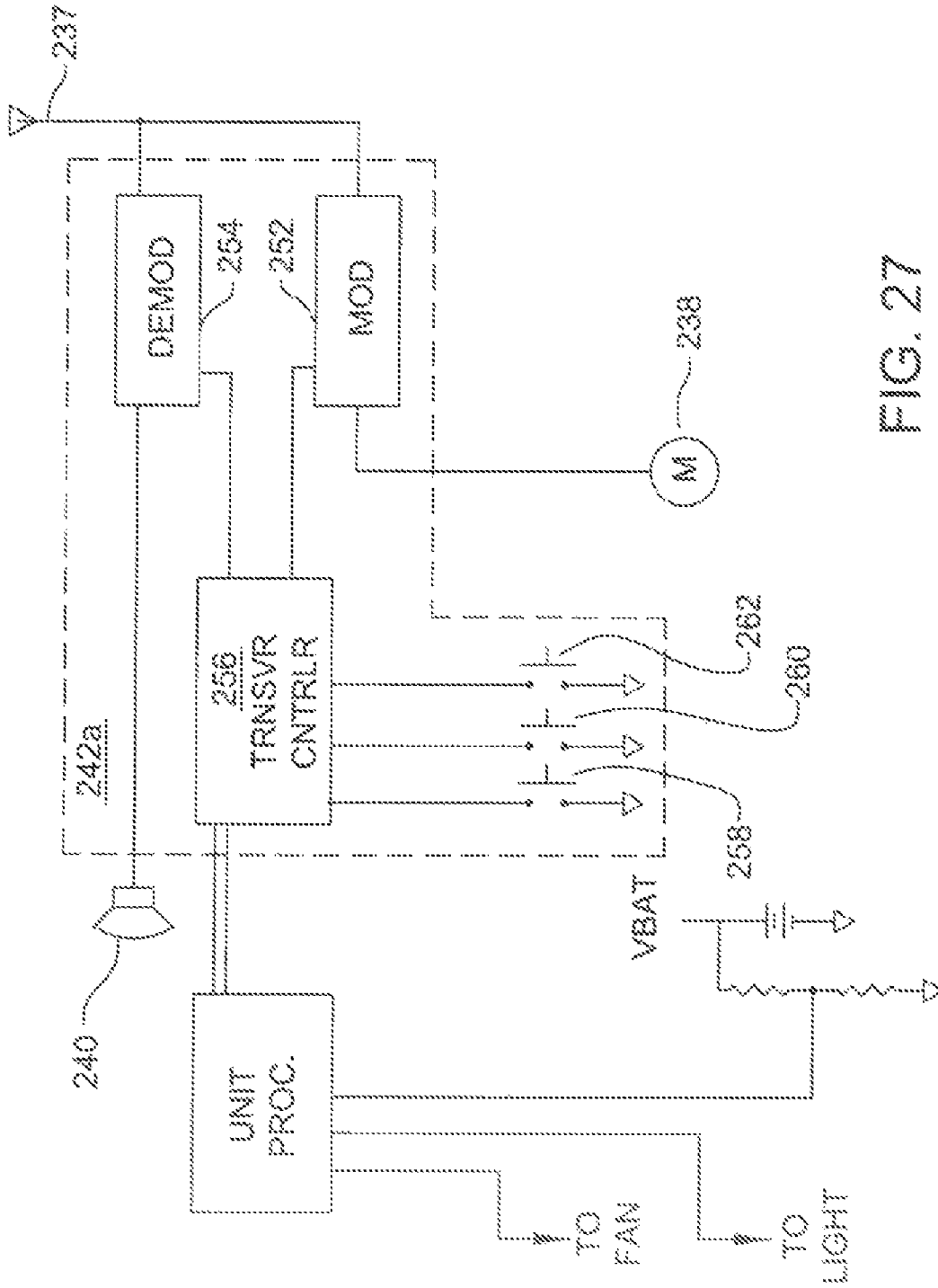

FIG. 27

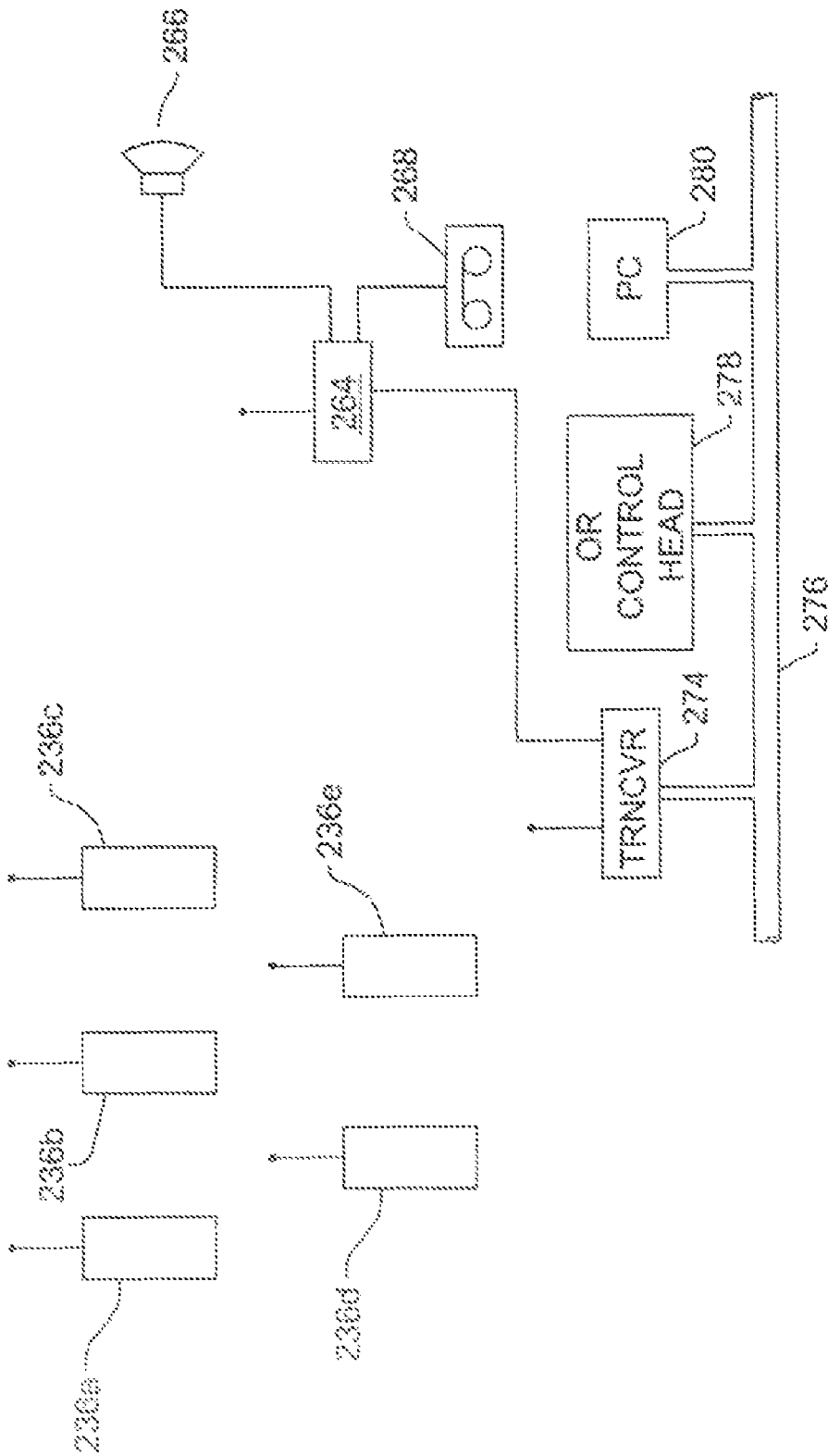

FIG. 28

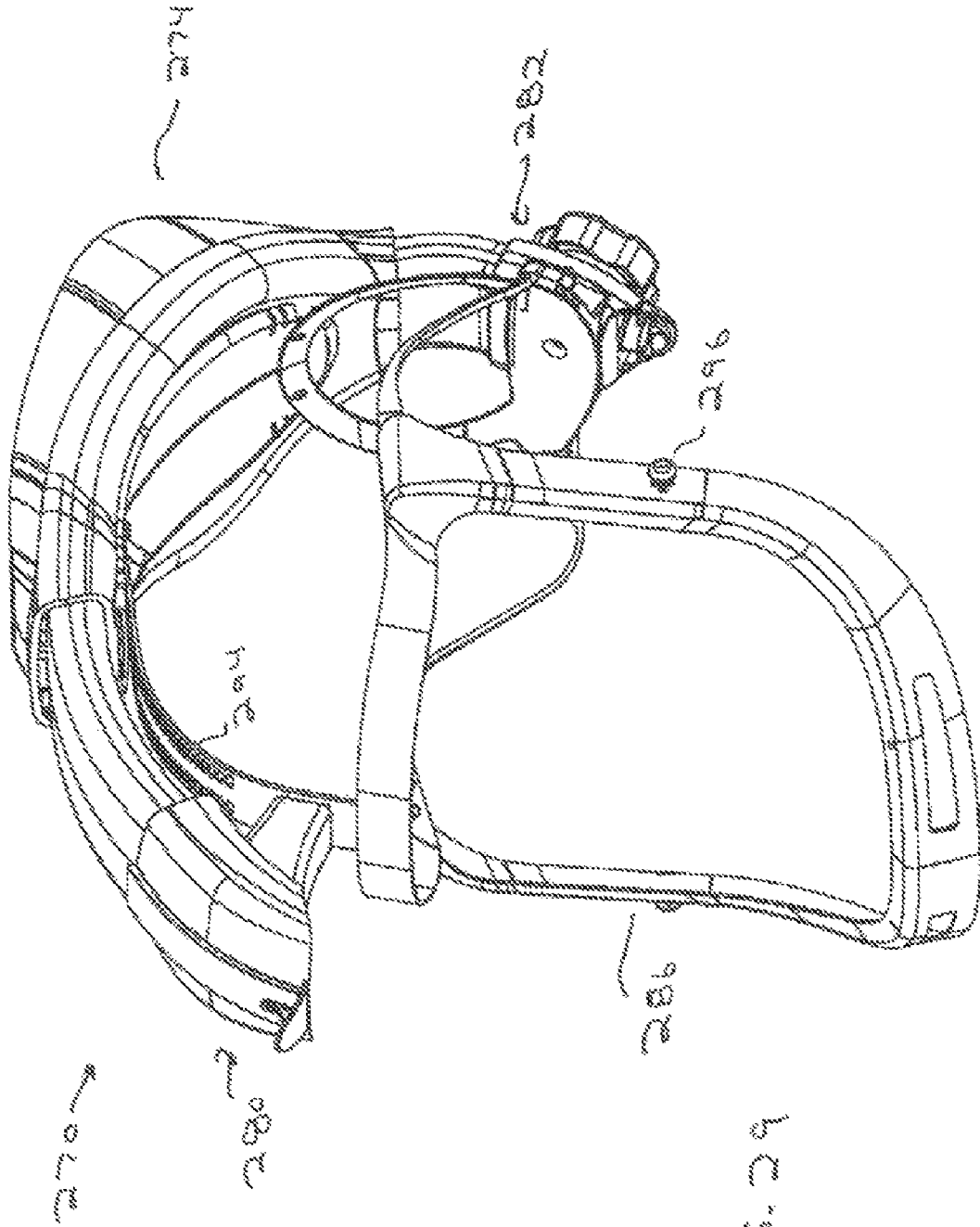
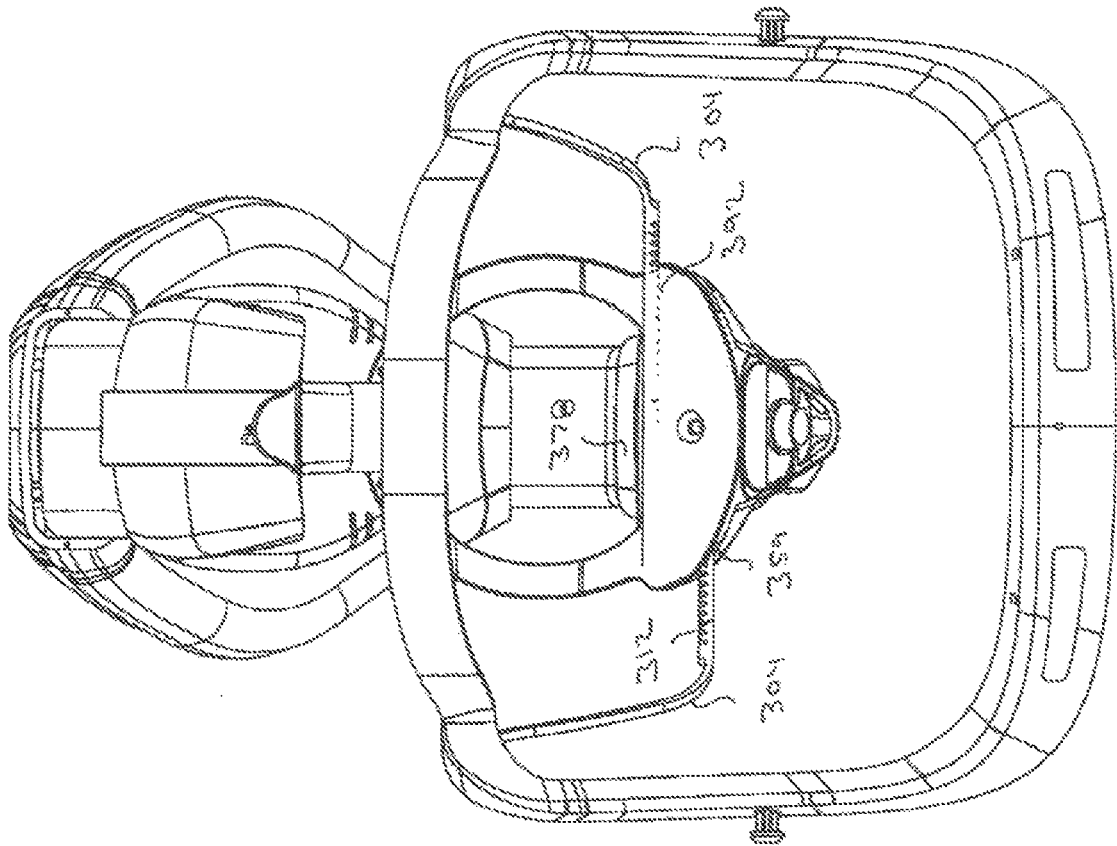

FIG. 29

FIG. 30



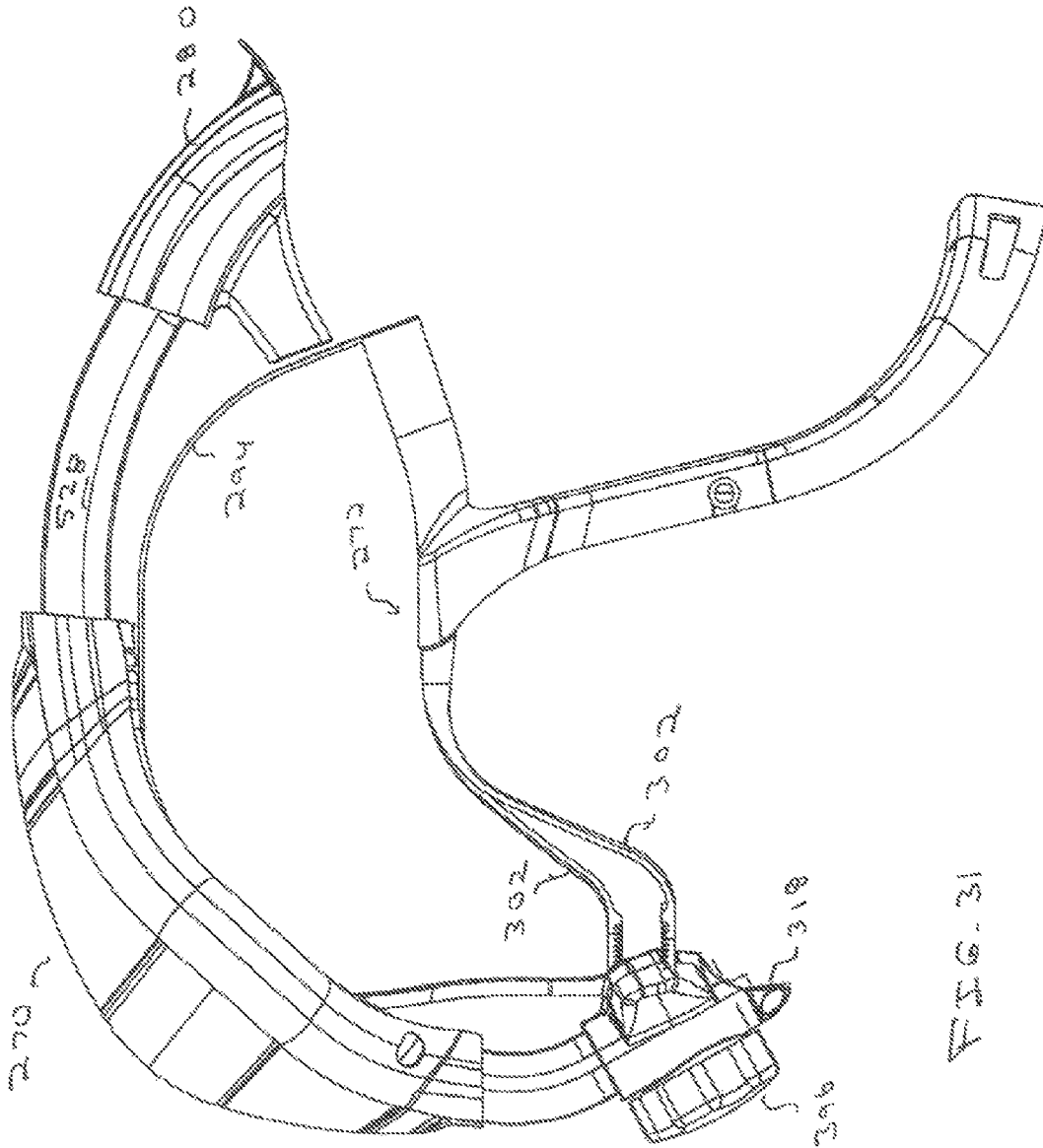

FIG. 31

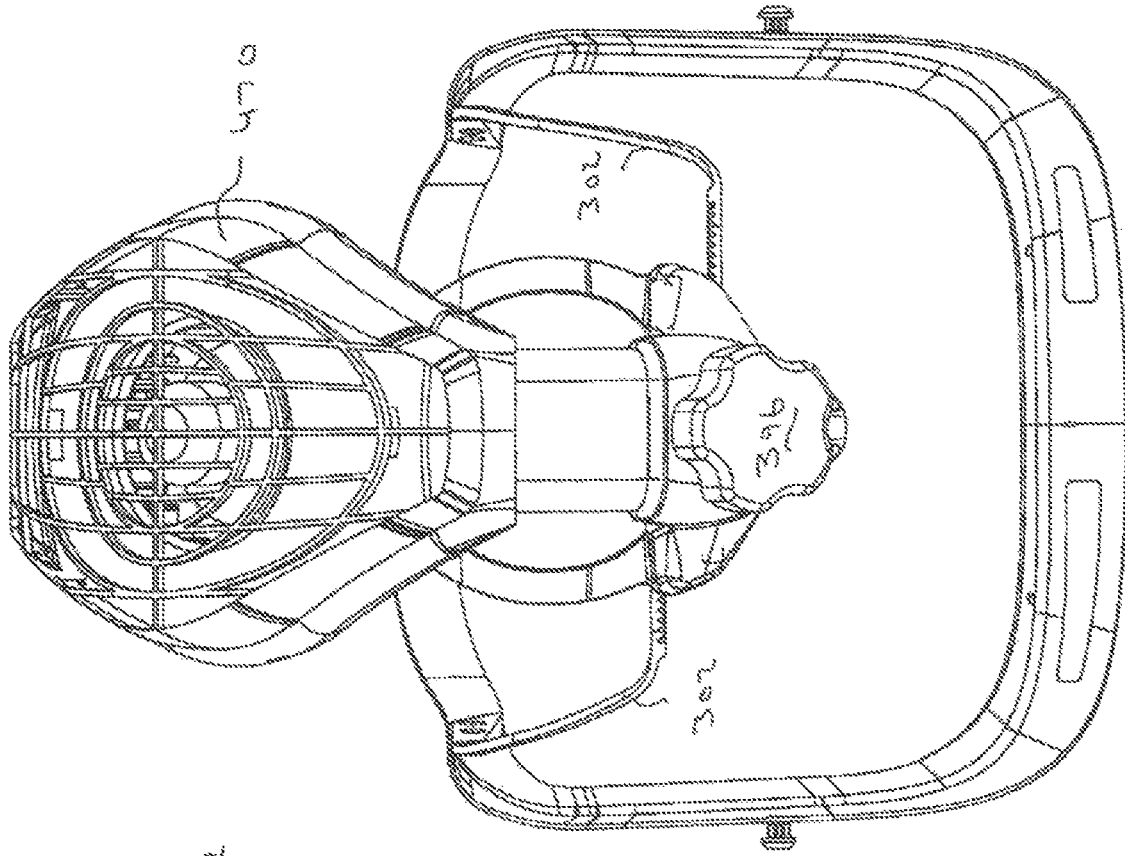

FIG. 32

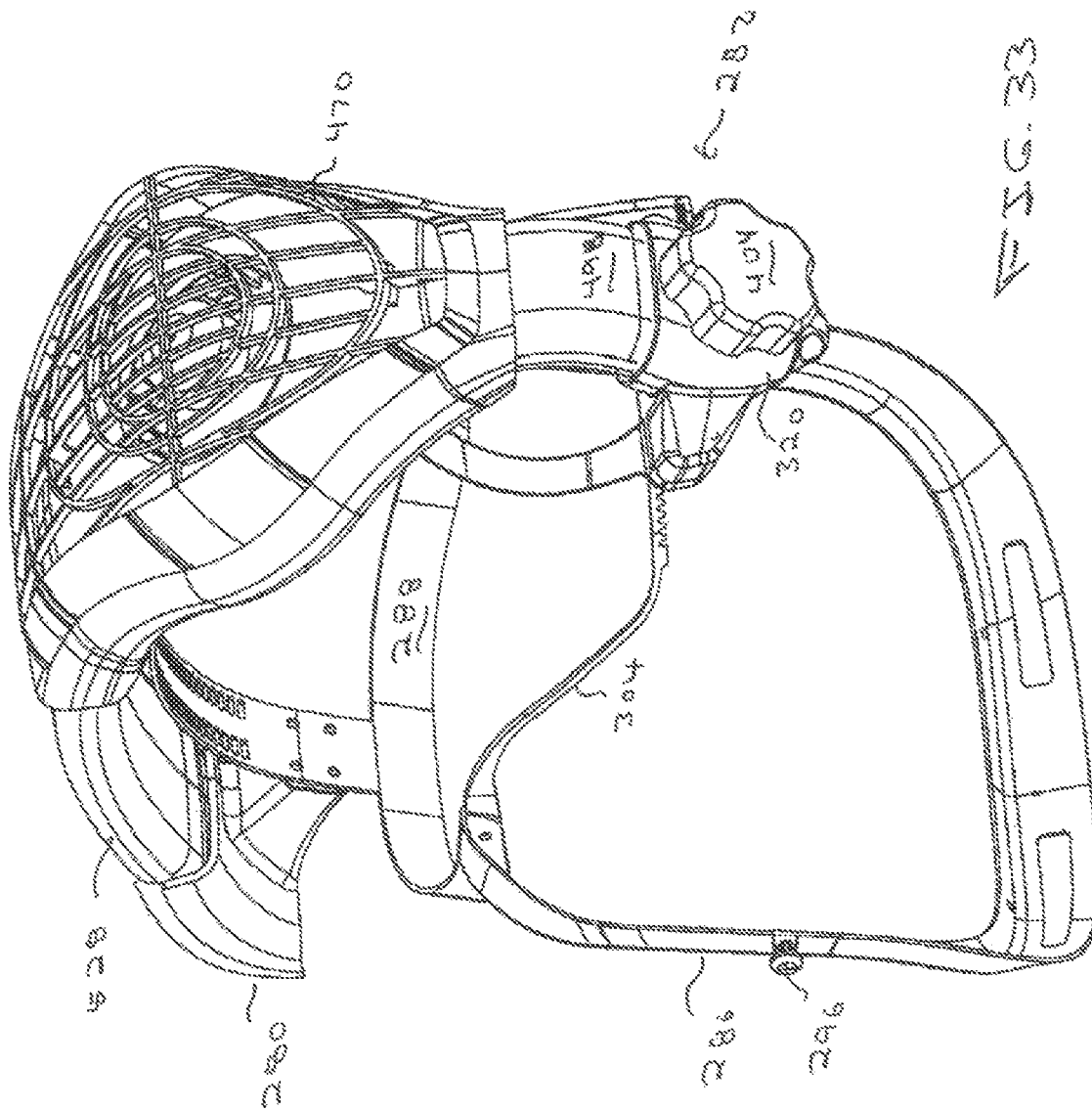
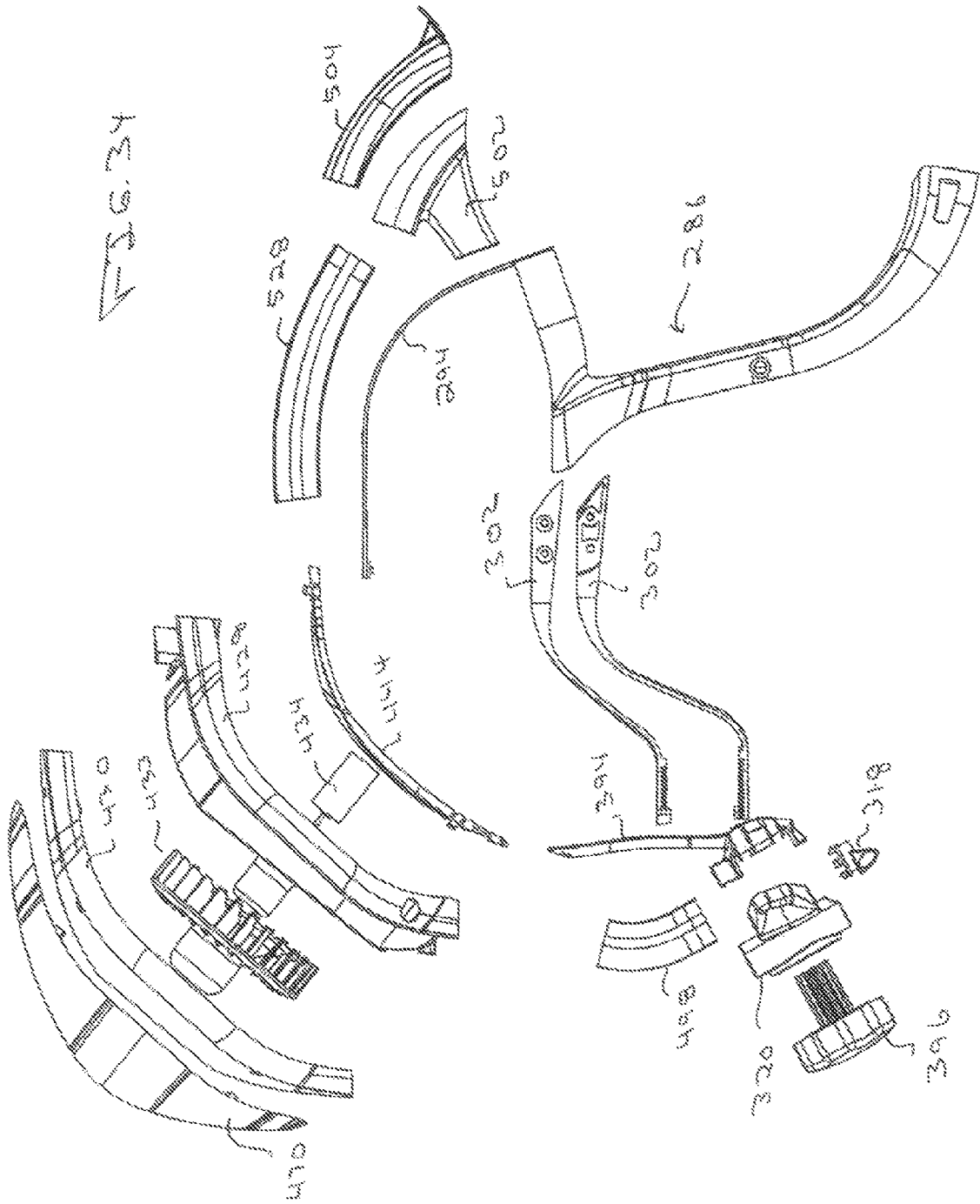

FIG. 33



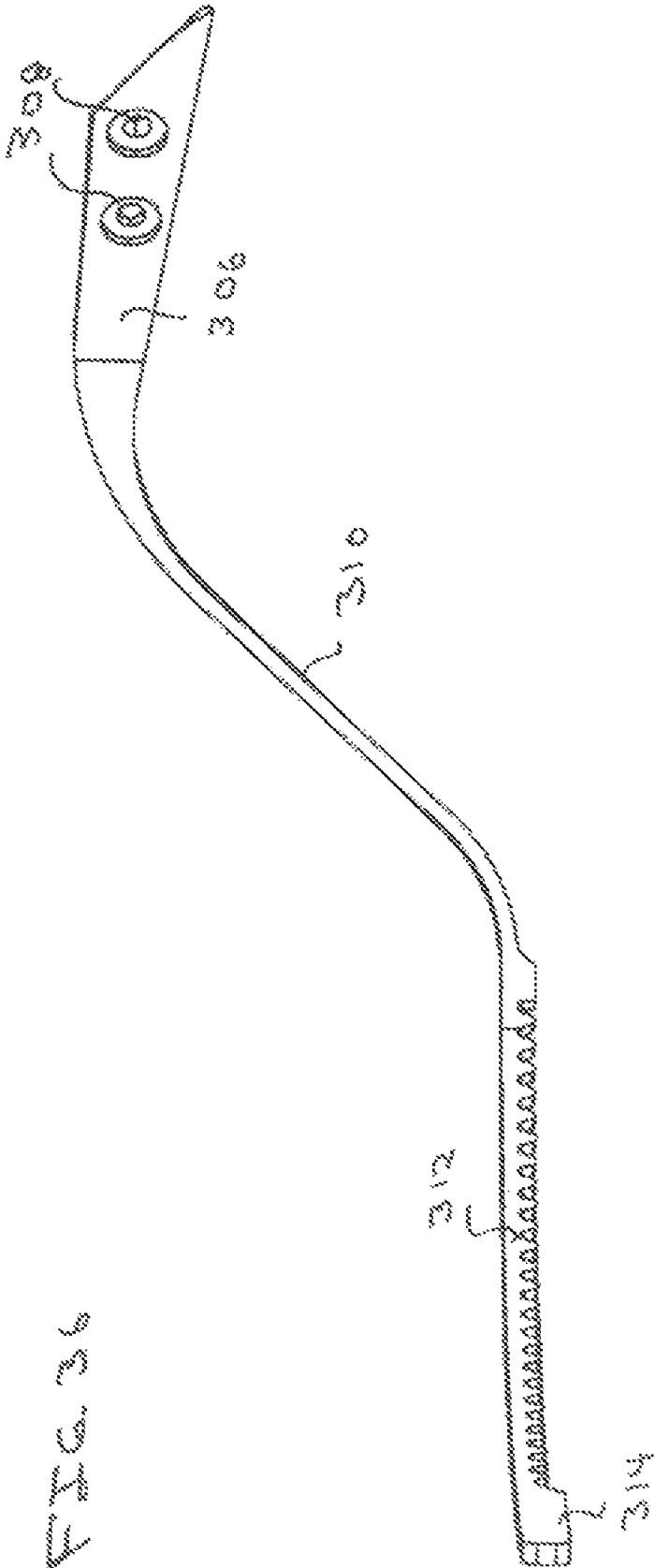

FIG. 36

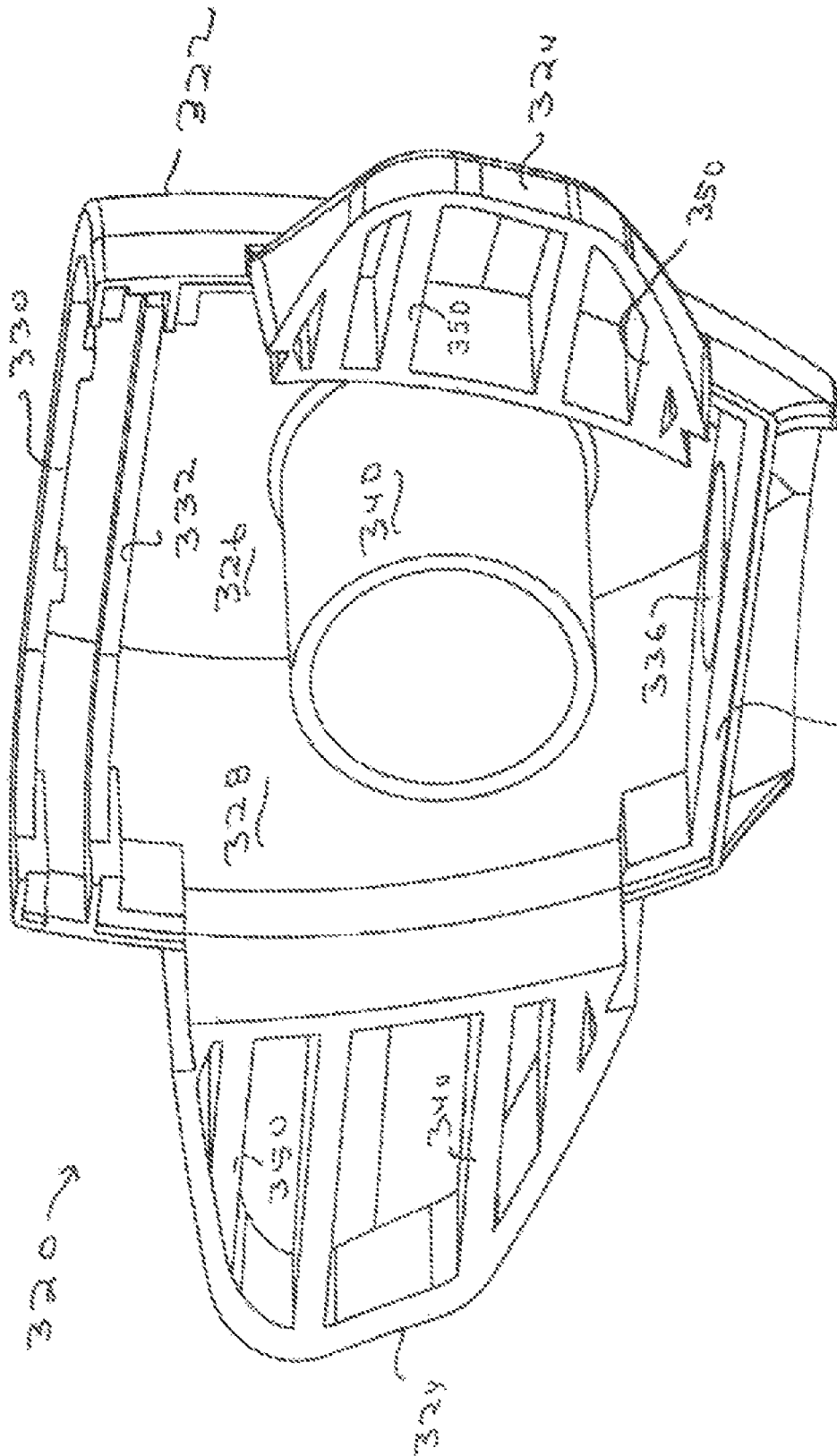

FIG 30

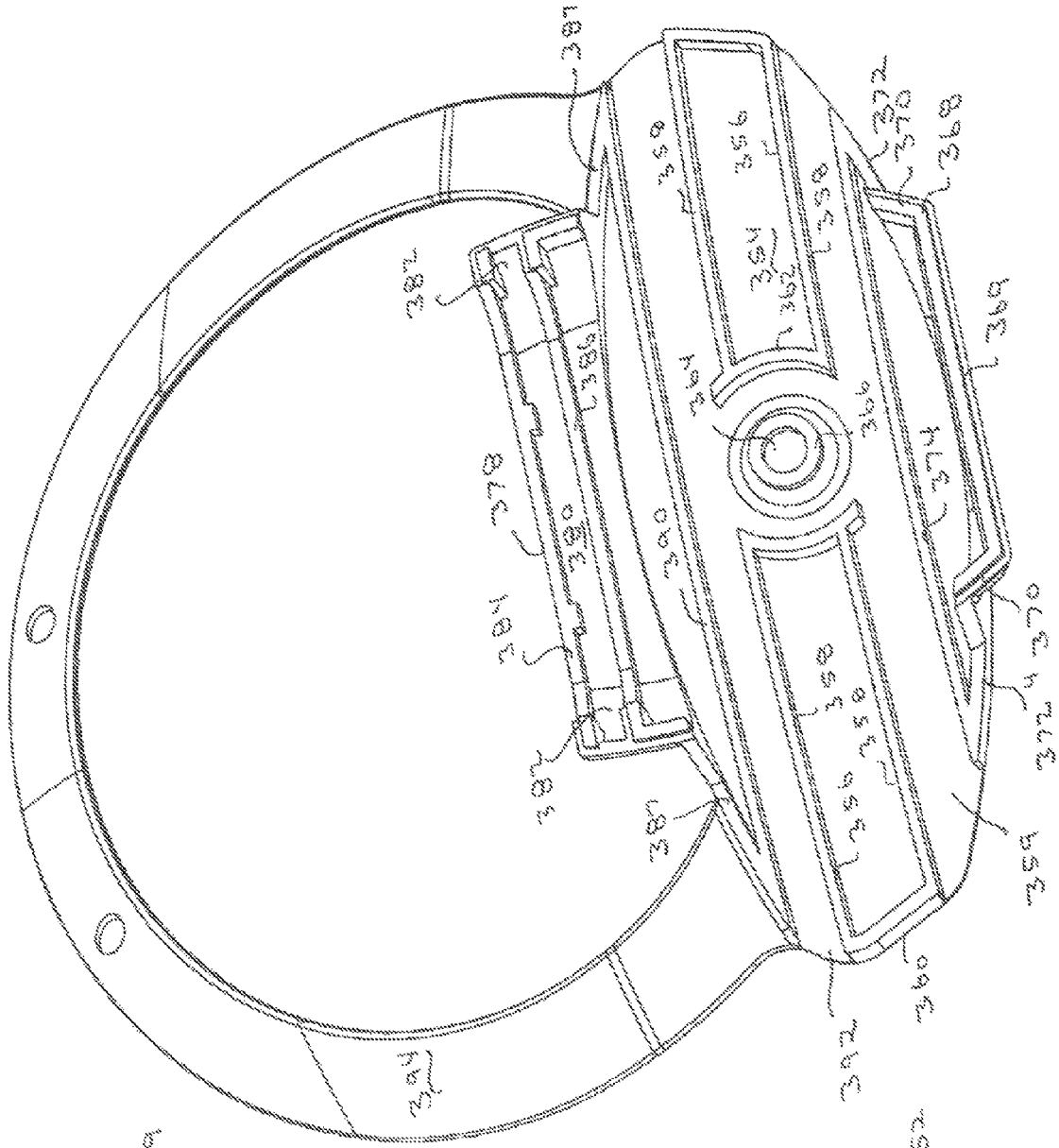
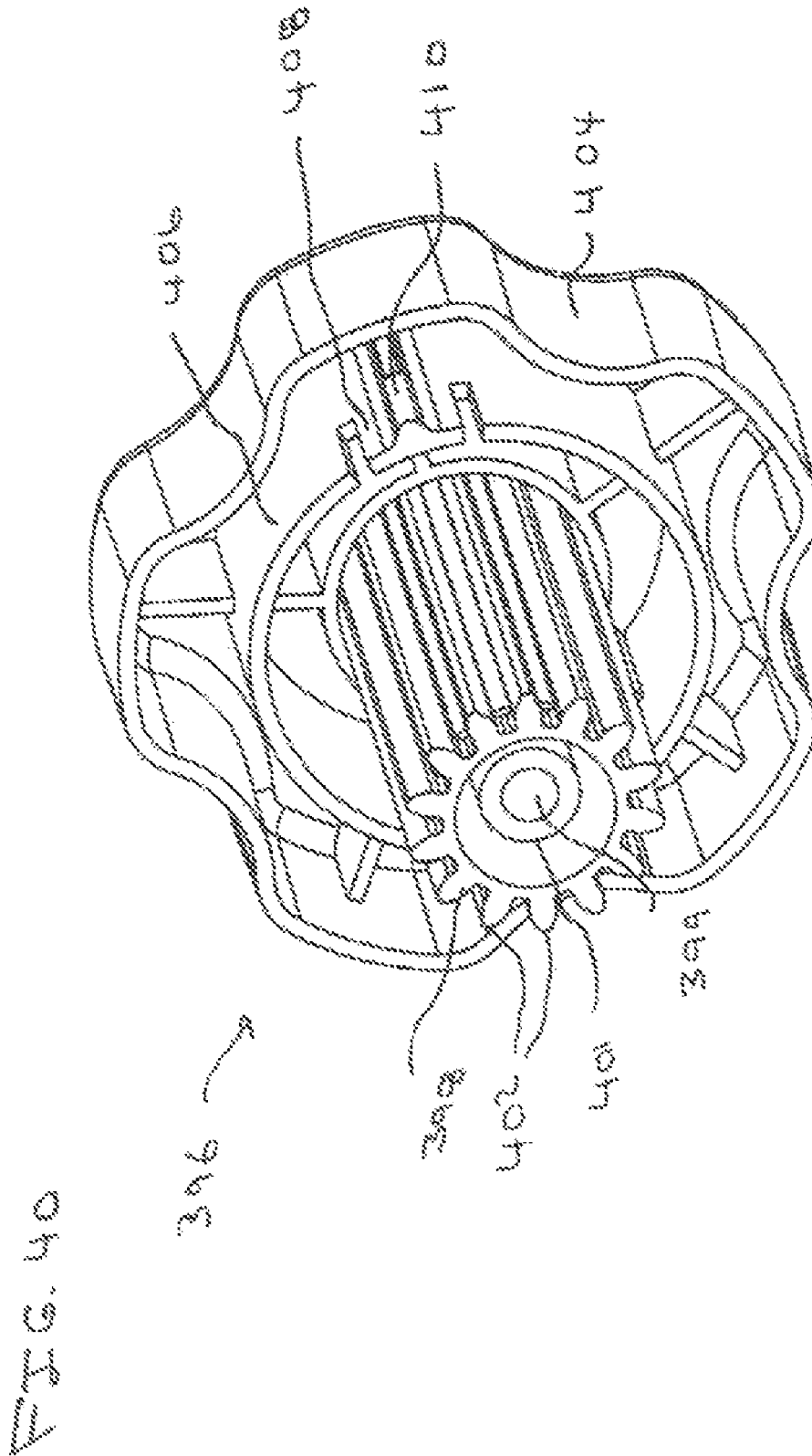
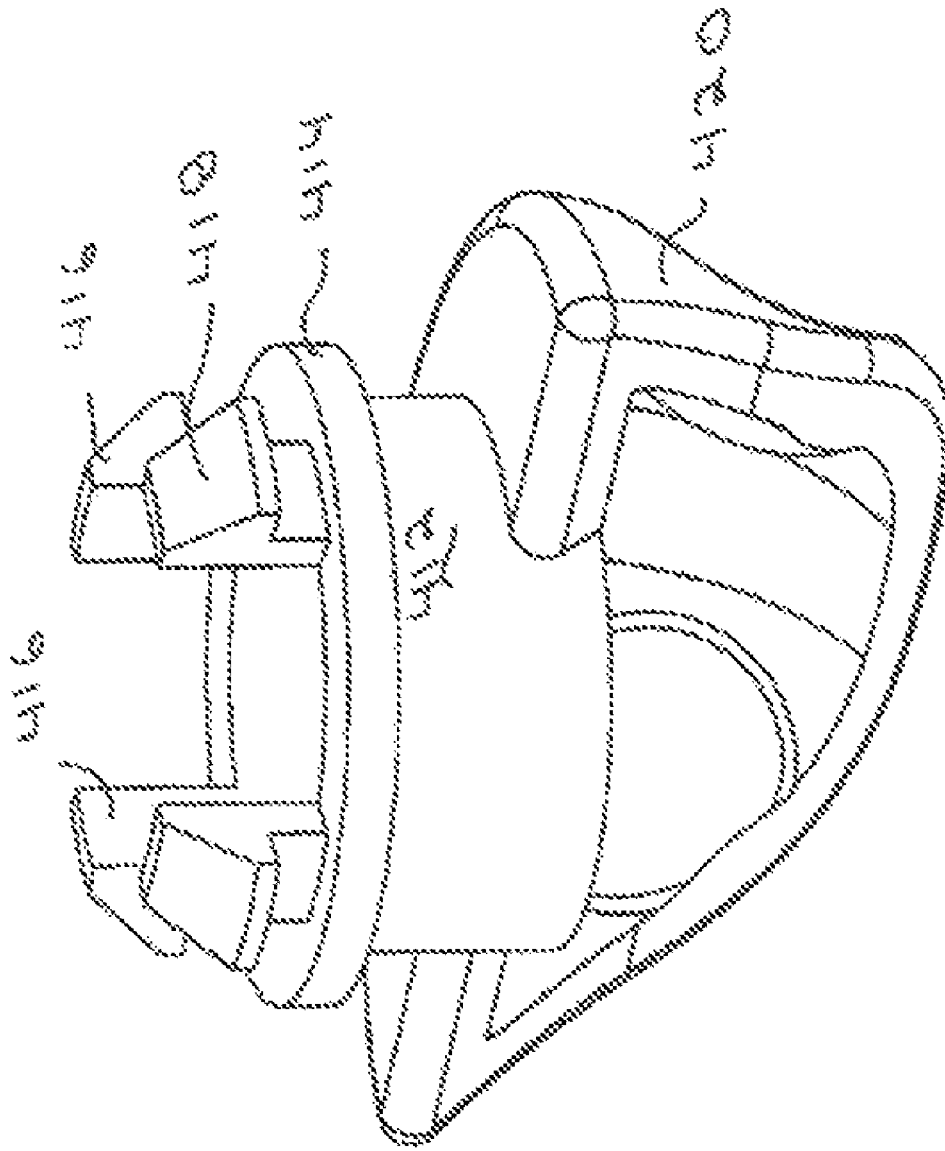

FIG. 39





4110

FIG. 41

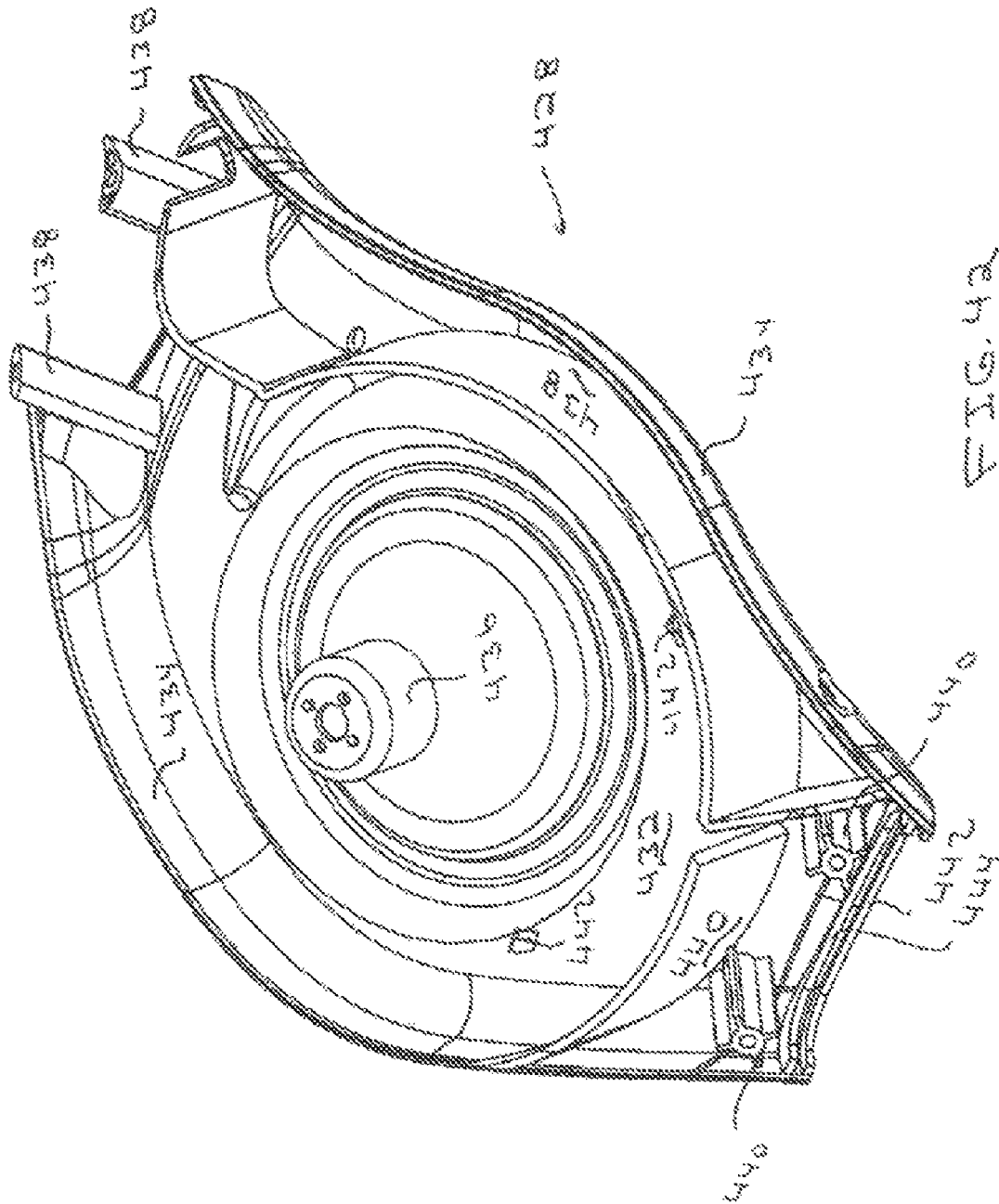
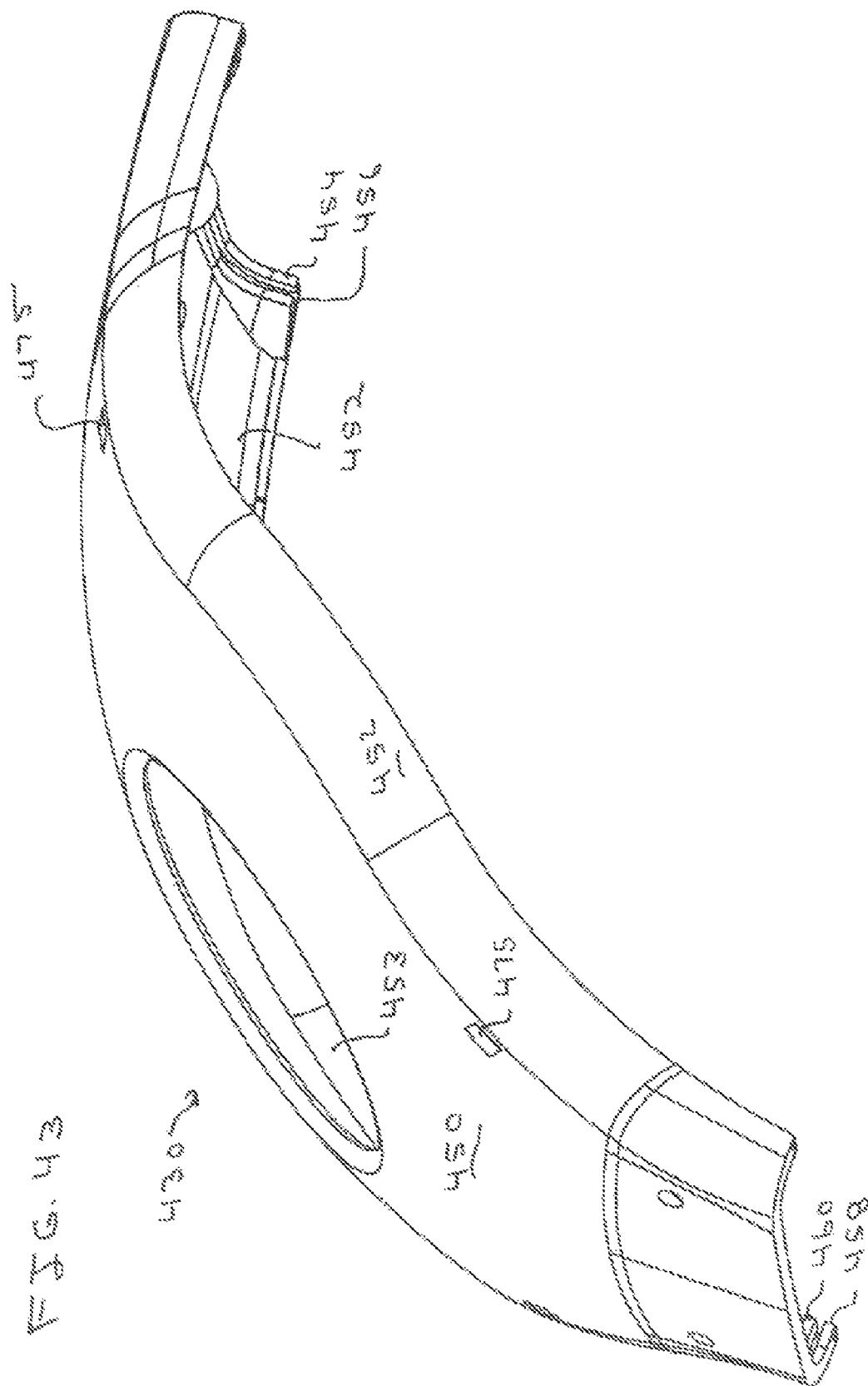

FIG. 42



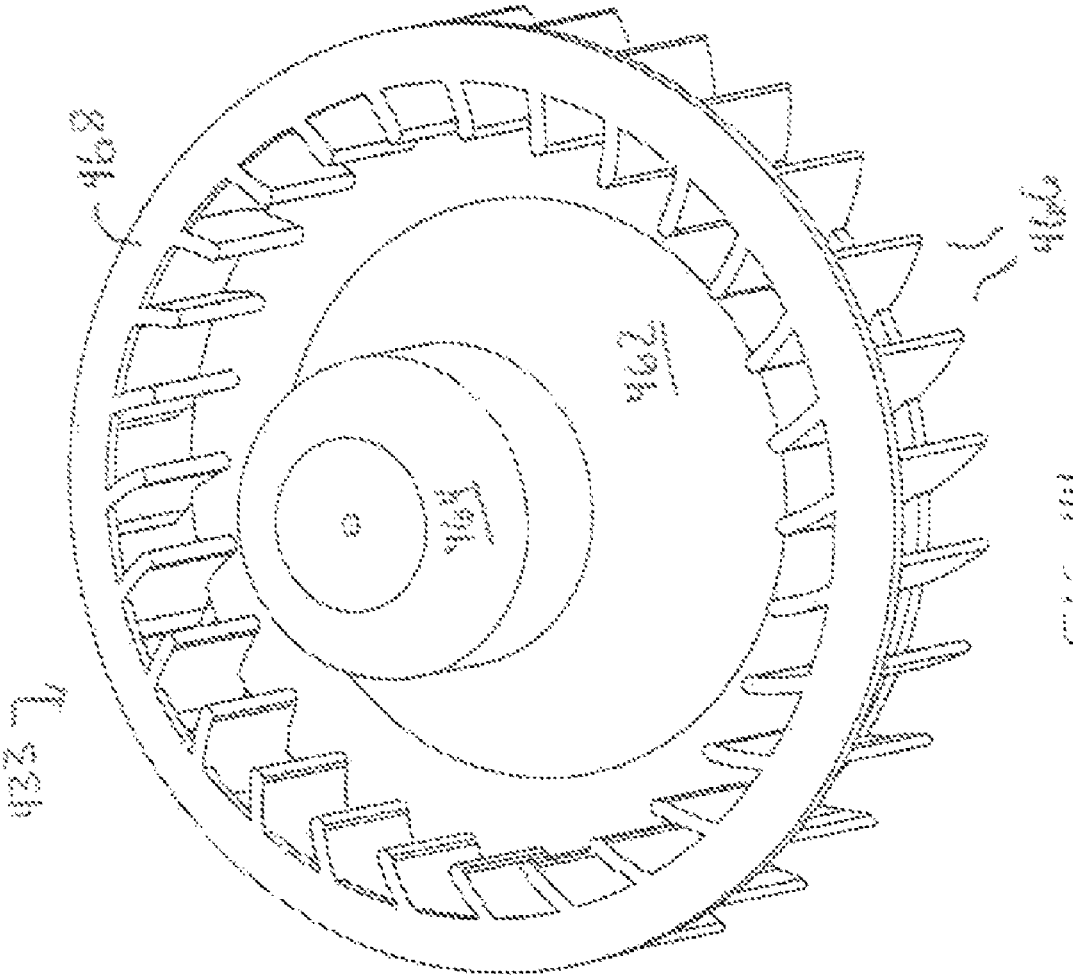

FIG. 94

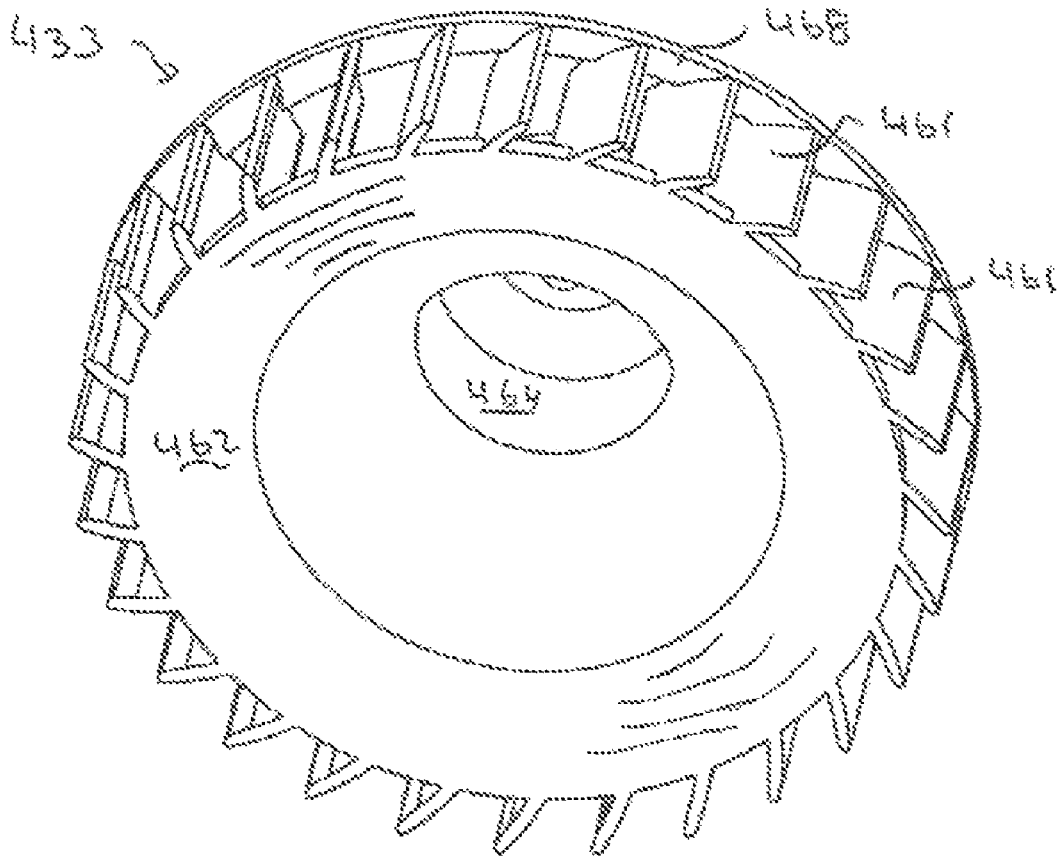

FIG. 44A

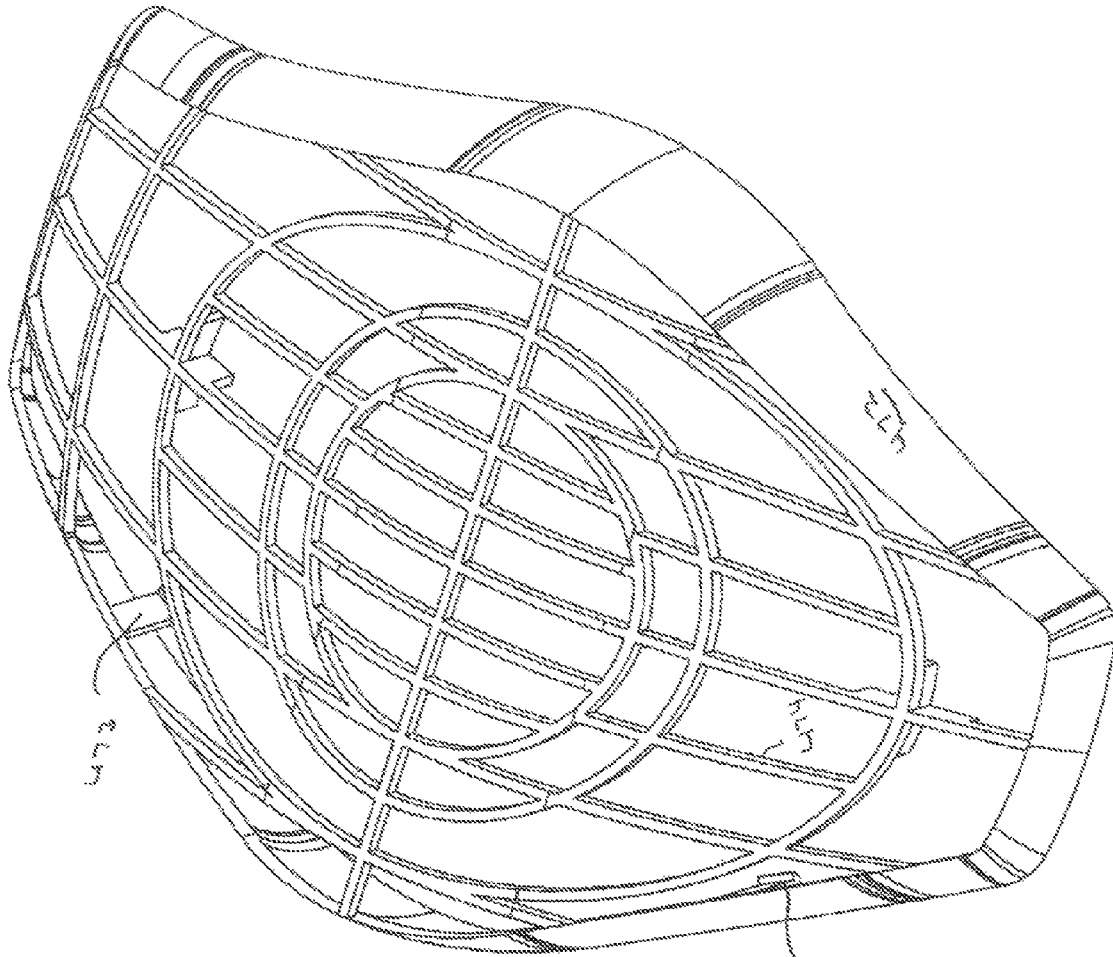

FIG. 45

470

472

473

471

FIG. 46

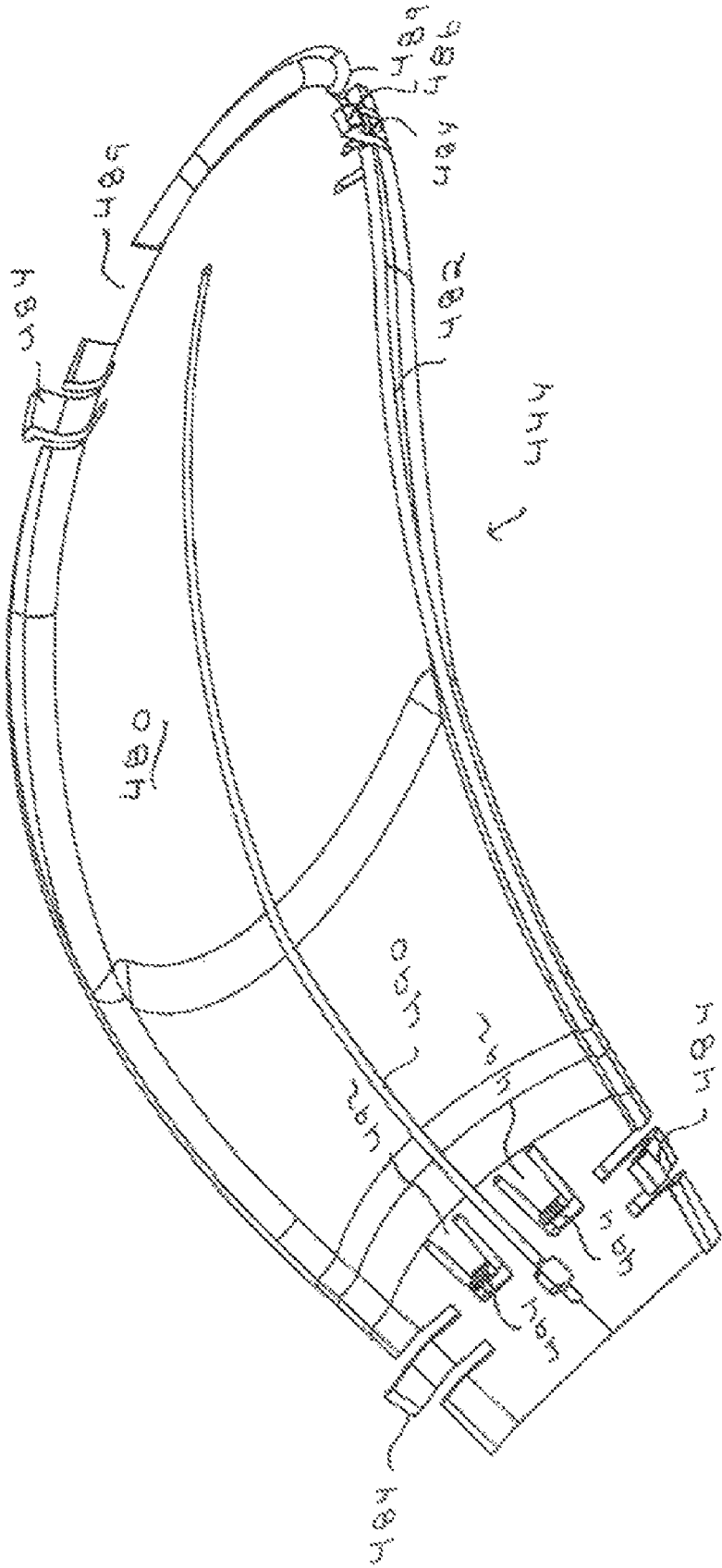

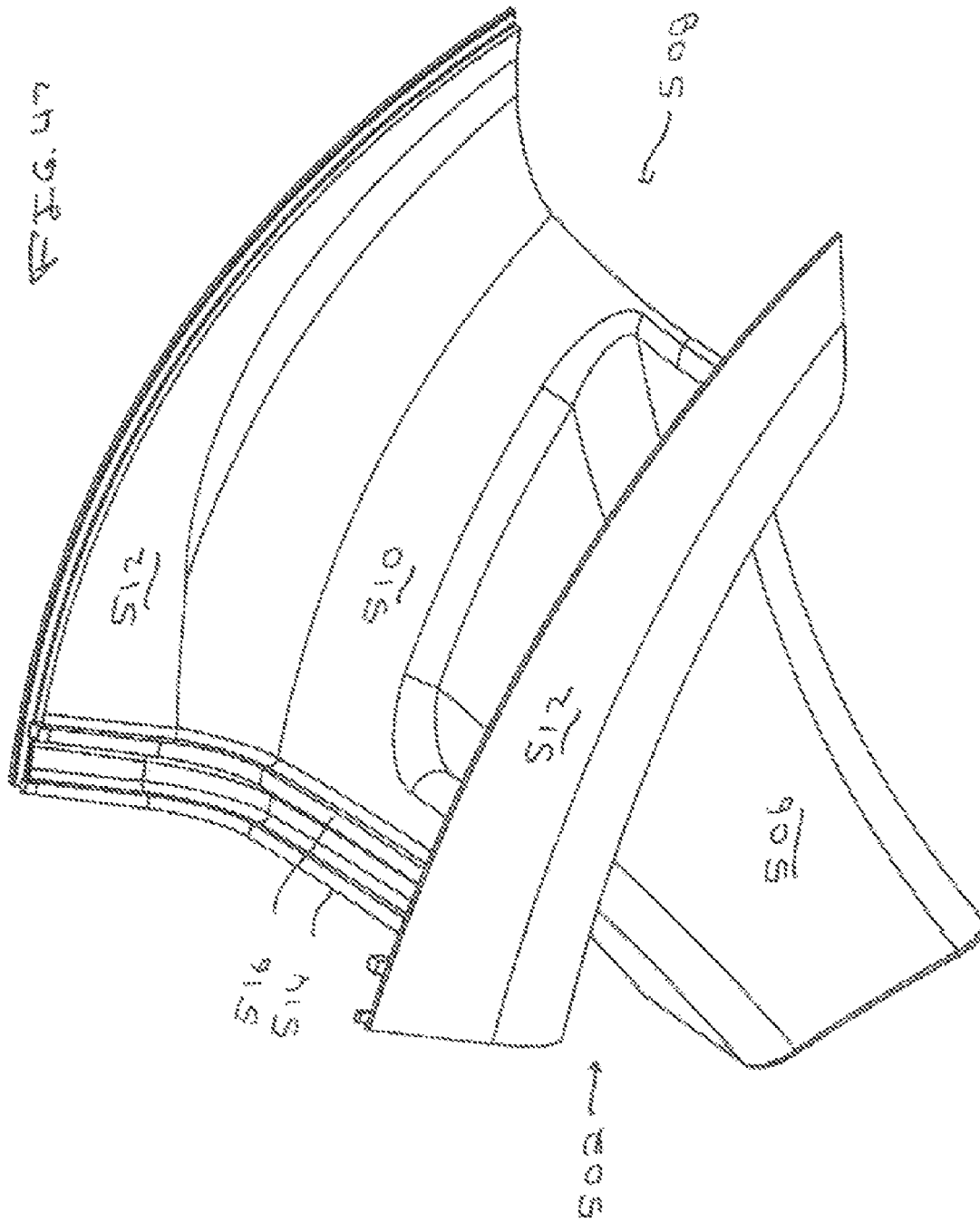
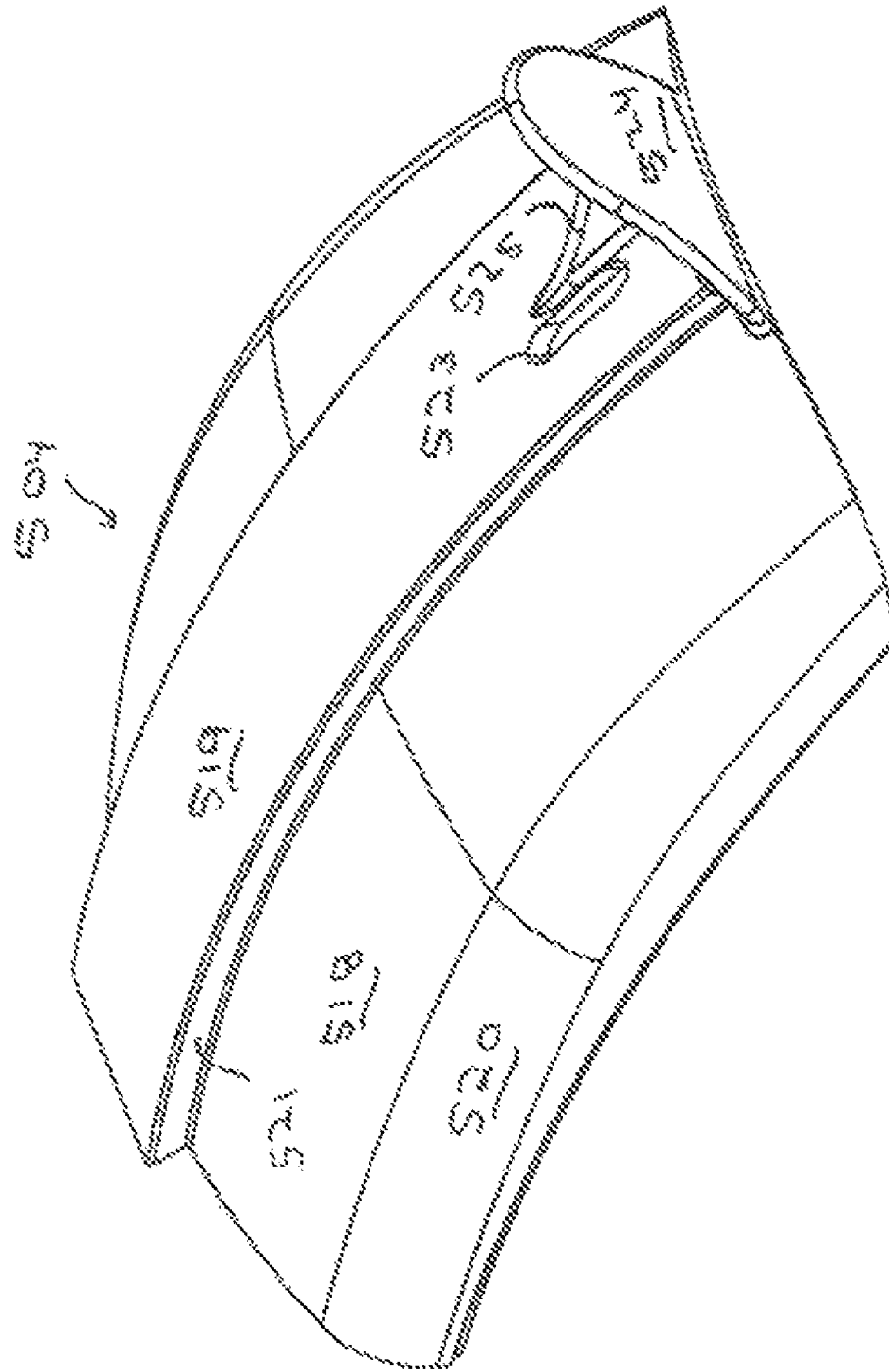

FIG. 4B



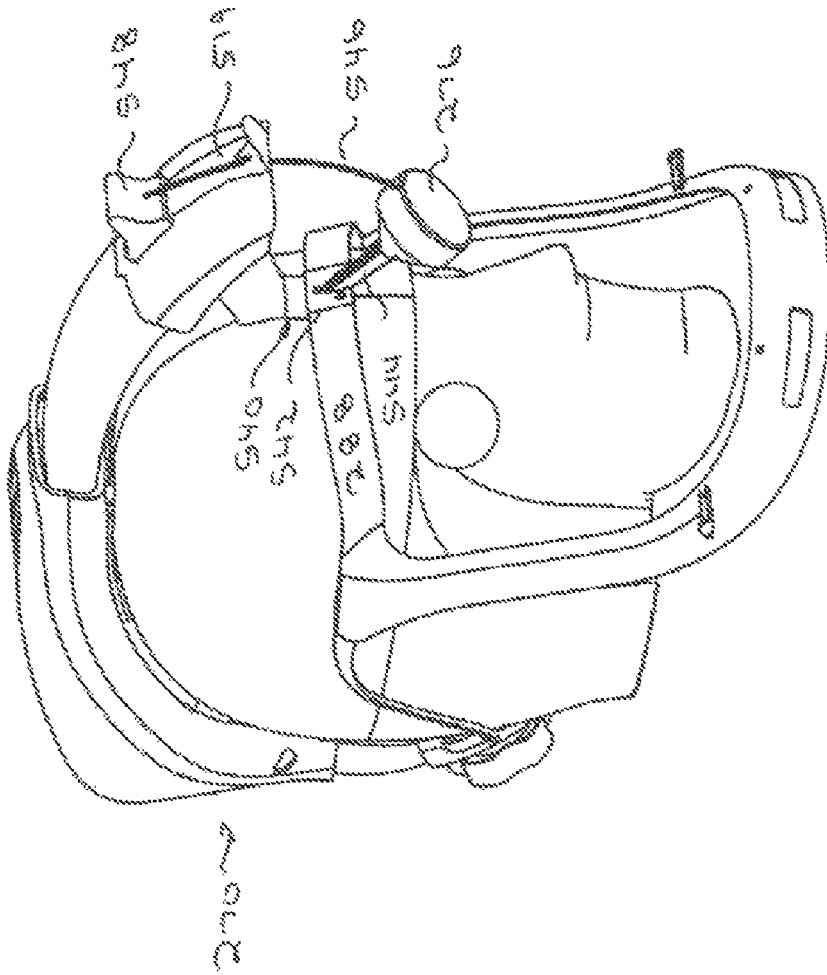
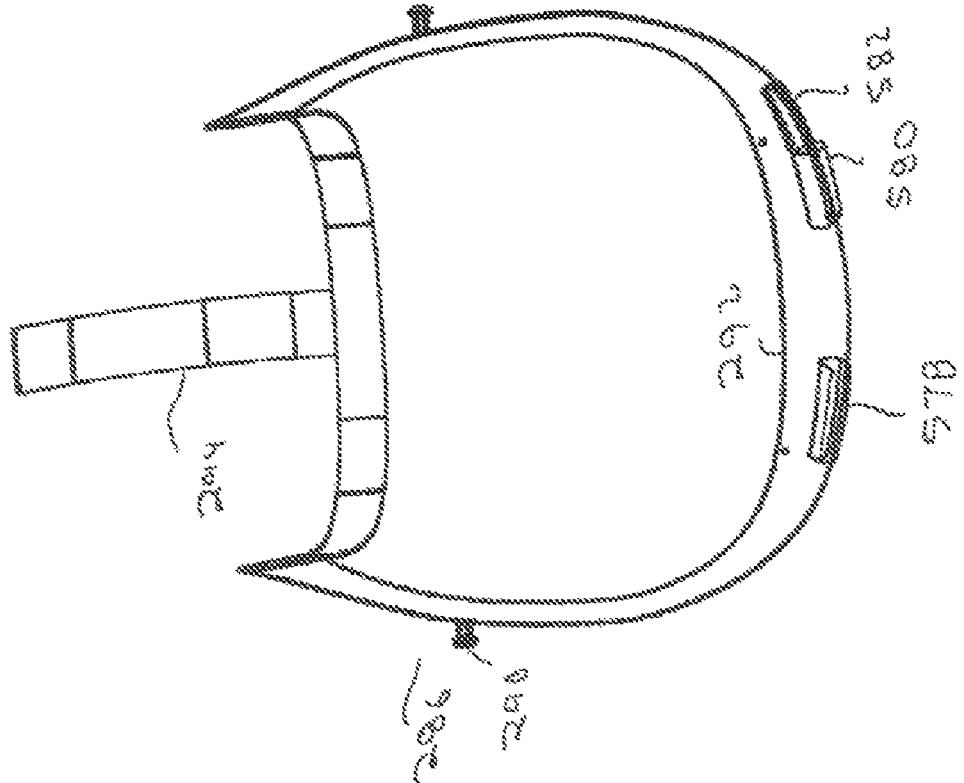
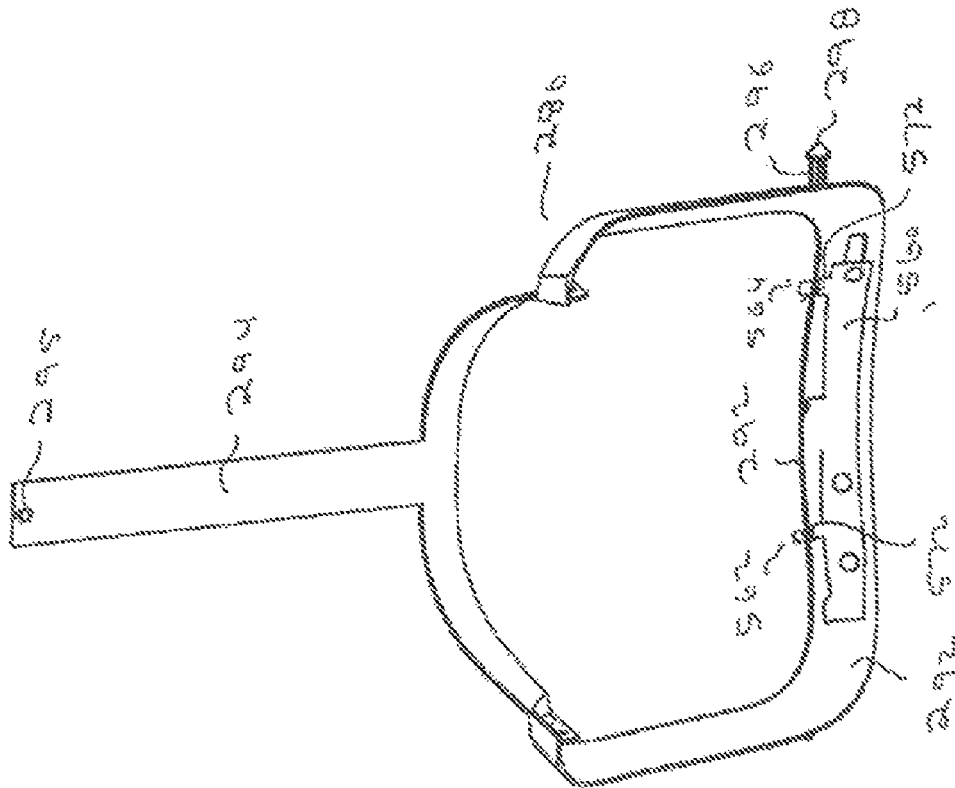

FIG. 49



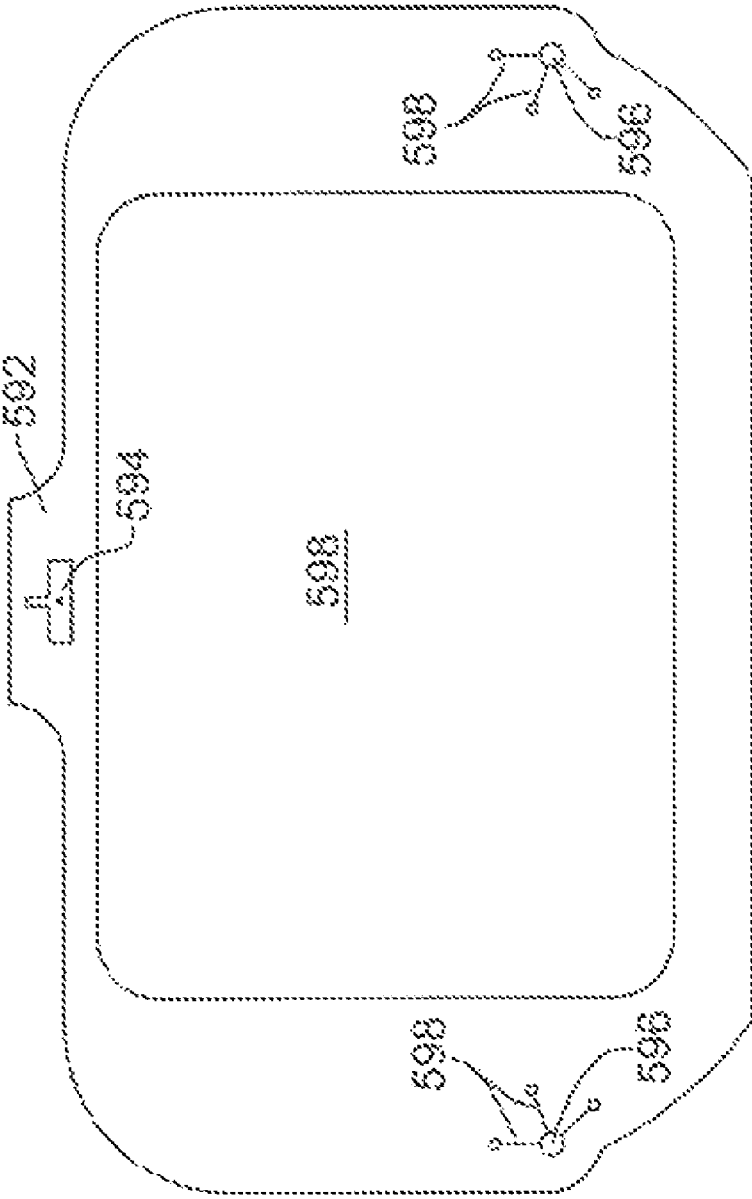

FIG. 52

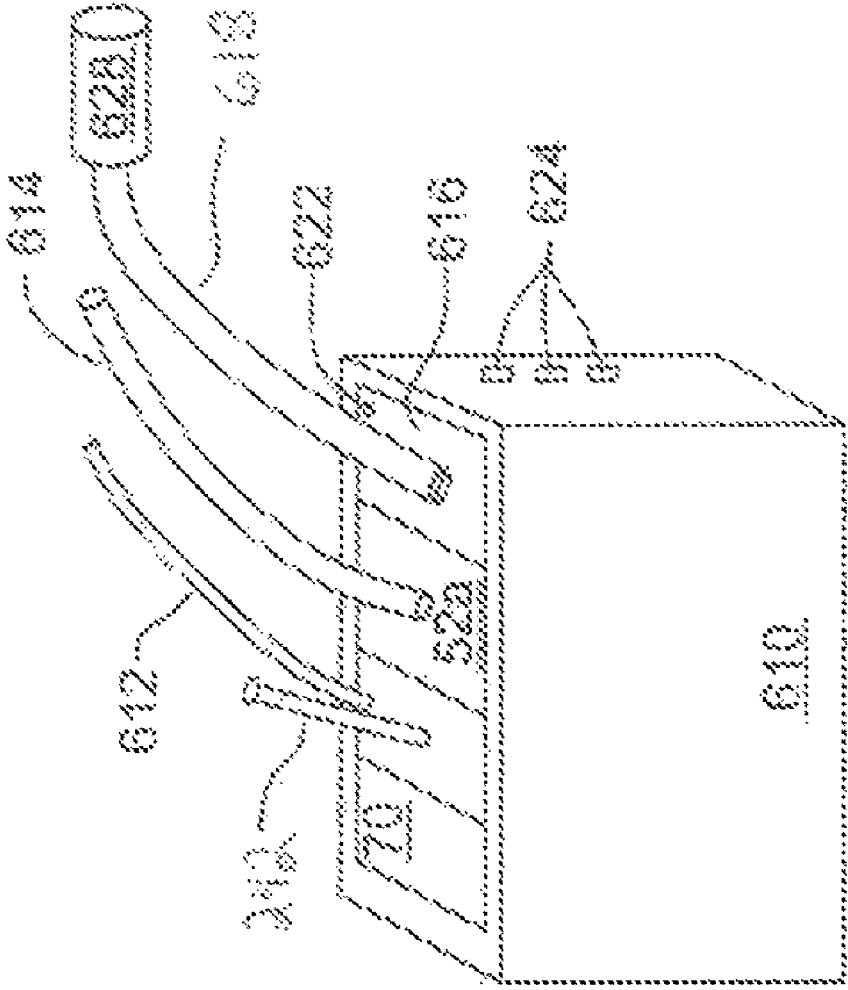

FIG. 53

1

**MEDICAL/SURGICAL PERSONAL
PROTECTION SYSTEM INCLUDING A
LIGHT ASSEMBLY ARRANGED SO THAT
HEAT GENERATED BY THE ASSEMBLY IS
EXHAUSTED AWAY FROM THE ASSEMBLY**

RELATIONSHIP TO EARLIER FILED
APPLICATIONS

This application is a divisional of application Ser. No. 11/485,783 filed 13 Jul. 2006 now U.S. Pat. No. 7,735,156, application Ser. No. 11/485,783 claims priority under 35 U.S.C. Sec. 119 from App. No. 60/699,166 filed 14 Jul. 2005.

FIELD OF THE INVENTION

The present invention generally relates to personal protection systems for use in medical environments, such as surgical environments, to protect both patients from contamination during surgical procedures, and to protect medical professionals from exposure to airborne contaminants and bodily fluids. More particularly, the system of this invention offers illumination, communication and reduces the physical strain imposed on the wearer.

BACKGROUND OF THE INVENTION

Personal protection systems are used in surgical procedures to provide a sterile barrier between the surgical personnel and the patient. One such system is disclosed in U.S. Pat. No. 5,054,480, the contents of which are incorporated herein by reference discloses that basic structure of such a system. Specifically, the traditional system includes a helmet that supports a toga or a hood. This assemblage is worn by medical/surgical personnel that want to establish the sterile barrier. The toga or the hood includes a transparent face shield. The helmet includes a ventilation unit that includes a fan. The ventilation unit draws air through the toga/hood so the air is circulated around the wearer. This reduces both the amount of heat that is trapped within the toga/hood and the CO₂ that builds up in this space. It is further known to mount a light to the helmet. The light, which is directed through face shield illuminates the surgical site.

Conventional personal protection systems do a reasonable job of providing a sterile barrier between the surgical personnel and the surrounding environment. However, there are some limitations associated with their use. The toga/hood that covers the wearer blocks sound waves. This means an individual wearing the system may have to speak loudly, even shout, to be heard. This is especially the case when the hooded individual is trying to communicate with another individual similarly attired.

Furthermore, while it is known to provide light with the helmet, it has proven difficult to provide a workable light. This is because in one proposed system, it is proposed that the actual light be emitted by a source at a static console. The light is supplied to the helmet for emission therefrom through a fiber optic cable. Thus with this system, the wearer is essentially tethered to the light source. This both limits the mobility of the individual and requires other operating room personnel to navigate around the tether. Alternatively, the light source could be mounted in the helmet. Such light sources generate heat. This heat can cause the temperature beneath the toga/hood to rise to an uncomfortable level.

2

Moreover, the helmet and the equipment it supports, places a load on the head of the wearer. Over time this load can impose an appreciable strain on the muscles and skeletal structure.

SUMMARY OF THE INVENTION

This invention relates to a new and useful personal protection system such as the type of system used to provide a sterile boundary around medical/surgical personnel.

The system of this invention includes a ventilation unit for supplying ventilation air underneath the toga/hood of wearer. There is a light unit. The light unit has a light source positioned in line with the air discharged from the ventilation unit. This arrangement minimizes the build up of heat around the light unit.

The system of this invention also includes an in-helmet mounted RF communications system.

The system of this invention also has a head unit that substitutes for a conventional helmet. The head unit includes a head band and a ventilation unit that is suspended above the head band. The ventilation unit is adjustably positioned relative to the head band. This allows the ventilation unit to be positioned relative to the head of the wearer so it is located where it will impose only a minimal strain on the wearer.

BRIEF DESCRIPTION OF THE DRAWINGS

Other advantages of the present invention will be readily appreciated as the same becomes better understood by reference to the following detailed description when considered in connection with the accompanying drawings wherein:

FIG. 1 is a perspective view of a helmet type personal protection system of this invention fitted over the head of a user;

FIG. 2 is a cross-sectional view of the helmet assembly;

FIG. 3 is an exploded perspective view of the helmet assembly;

FIG. 3A is a plan view of the front of the scroll housing;

FIG. 3B is a plan view of the rear of the scroll housing;

FIG. 4 is a perspective view of the head band;

FIG. 5 is a side view of the helmet assembly with a toga and hood with face shield;

FIG. 6 is a perspective view of the helmet assembly illustrating a positioning and supporting system including a mounting clip supporting the face shield via an aperture in the face shield;

FIG. 7 is a side view of the helmet assembly implementing a light assembly;

FIG. 8 is a bottom view of the helmet assembly implementing the light assembly;

FIG. 9 is a back view of the helmet assembly implementing the light assembly;

FIG. 10 is a cross-sectional view of the helmet assembly along the line 10-10 shown in FIG. 9;

FIG. 11 is a bottom view of the helmet assembly implementing the light assembly;

FIG. 12 is a cross-sectional side view of the helmet assembly showing a printed circuit board disposed within the helmet assembly;

FIG. 13 is a front view of the helmet assembly;

FIG. 14 is a side view of the helmet assembly showing a handle for adjusting the angle of the light assembly;

FIG. 15 is a side view of the helmet assembly;

FIG. 16 is a perspective back view of the helmet assembly along the line 16-16 shown in FIG. 15;

3

FIG. 17 is a partial exploded view of the helmet assembly showing the components of an light adjustment mechanism for adjusting the angle of the light assembly;

FIG. 18 is a perspective view of the helmet assembly;

FIG. 19 is a bottom view of the helmet assembly;

FIG. 20 is an electrical block diagram illustrating the flow of electricity from a power supply to a motor and a light source;

FIG. 21 is an electrical schematic diagram showing the relationship between electronic components disposed on the circuit board;

FIG. 22 is an electrical block diagram of a communications system;

FIG. 23 is a side view of the helmet assembly illustrating a microphone of the communications system;

FIG. 24 is a front view of the helmet assembly illustrating the microphone and a speaker of the communications system;

FIG. 25 is a side view of the helmet assembly illustrating the microphone and the speaker of the communications system;

FIG. 26 is a block diagram of how, in some versions of this invention, a single power supply provides the energization current for the fan motor, the light source and the communications transceiver;

FIG. 27 is a block diagram of the components internal to a transceiver of this invention;

FIG. 28 is a diagrammatic illustration of how signals are exchanged between different communications units of this invention;

FIG. 29 is a perspective view of an alternative head unit of the personal protection system of this invention;

FIG. 30 is a front view of the head unit;

FIG. 31 is a side view of the head unit;

FIG. 32 is rear view of the head unit;

FIG. 33 is a rear perspective view of the head unit;

FIG. 34 is an exploded view of the head unit;

FIG. 35 is a perspective view of the face frame;

FIG. 36 is a plan view of one of the head straps;

FIG. 37 is view of the outside of the rear nozzle assembly shell;

FIG. 38 is a view of the inside of the rear assembly shell;

FIG. 39 is a perspective view of the inside of the plate of the rear nozzle assembly;

FIG. 40 is a perspective view of the knob integral with the rear nozzle assembly;

FIG. 41 is a perspective view of tip of the rear nozzle assembly;

FIG. 42 is a view of the inside of the lower shell of the ventilation unit;

FIG. 43 is a perspective view of the upper shell of the ventilation unit;

FIG. 44 is a perspective view of the ventilation unit fan;

FIG. 44A is a perspective view of the underside of the fan.

FIG. 45 is a perspective view of the ventilation unit grill unit;

FIG. 46 is a perspective view of the ventilation unit motor cover;

FIG. 47 is a perspective view of the front nozzle assembly pedestal;

FIG. 48 is a perspective view of the front nozzle assembly cap;

FIG. 49 is a perspective view illustrating how the light is adjustably mounted to the head unit;

FIG. 50 depicts how the flex circuit is attached to the front frame chin bar;

FIG. 51 depicts how switches are mounted to the front frame chin bar;

4

FIG. 52 is a plan view of the hood/toga transparent shield used with the head unit; and

FIG. 53 is a block diagram of how the power supply, the fan, the transceiver and light generating source of the personal protection system of this invention are contained in a common housing.

DETAILED DESCRIPTION OF THE INVENTION

I. Overview

Referring to the Figures, wherein like numerals indicate like or corresponding parts throughout the several views, a personal protection system is generally shown at 10.

The personal protection system 10 is adapted from the personal protection system 10 disclosed in U.S. Pat. No. 6,481,019 to Diaz et al. and U.S. Provisional Patent Application No. 60/664,900, both of which are hereby incorporated by reference. The personal protection system 10 of the present invention is implemented as a helmet assembly 12 mountable to the head 14 of a user, as shown in FIG. 1.

The personal protection system 10 filters air between the head 14 and body 16 of a user, e.g., a medical professional, and an environment external to the user. The helmet assembly 12 distributes air about the head 14 of the user as will be described below. More specifically, the helmet assembly 12 distributes air toward both a front of the head 14, i.e., a face of the user, and a back of the head 14, i.e., a neck of the user.

Referring to FIG. 2, the helmet assembly 12 includes a shell 17 having an inner shell portion 18 facing the user and an outer shell portion 20 facing away from the user. The outer shell portion 20 is spaced apart from the inner shell portion 18 to define at least one air flow channel 26 between the inner and outer shell portions 18, 20. It is to be understood that the present invention may include more than one discrete air flow channel 26. The illustrated embodiment includes a single unitary air flow channel 26 and the present invention will be described below in terms of this air flow channel 26. The shell 17 is preferably formed of acrylonitrile butadiene styrene (ABS), but may be formed, in alternative plastics.

The helmet assembly 12 also includes a facial section 40 extending from the shell 17 to define a facial opening 42. The facial section 40 of the helmet assembly 12 is a chin bar 44. The chin bar 44 is flexible and is formed of plastic such as polypropylene. The flexibility of the chin bar 44 protects the wearer's face and absorbs impact when the user contacts an external object with the helmet assembly 12. The chin bar 44 also holds the hood 92 (FIG. 1) away from the face of the wearer.

II. Helmet

Referring to FIGS. 2-3, the helmet assembly 12 includes a fan module 46 mounted in a cavity 38 in the shell 17. Fan module 46 includes a fan 50 and a motor 52 mounted to a scroll housing 48. Fasteners M that extend through the shell 17 into threaded bores in the housing 48 to hold the module 46 in cavity 38 (housing bores not shown). A cover plate 47 is fixed to the shell 17 below cavity 38 to cover the fan module 46. A cushion 49 is disposed between the cover plate 47 and a base of the fan module 46. The cushion 49 absorbs the sound emitted by the fan motor 52. This reduces the amount of noise emitted by the system 10 of this invention. The scroll housing 48 may be formed of glass-filled polypropylene to reduce vibrations.

The helmet assembly 12 further includes an intake grid 100 mounted to the outer shell portion 20. The intake grid 100 includes a top surface spaced from the outer shell portion 20 of the helmet assembly 12. The intake grid 100 is contoured to

the outer shell portion **20** between the front and rear of the shell **17**. Air is drawn into the scroll housing **48** through the intake grid **100** by the fan **50**.

Also shown in FIG. 3 are various fasteners and washers, not identified, that secure the components forming helmet assembly **12** together.

In operation, the motor **52** rotates the fan **50** to draw air into the air inlet **64** of the scroll housing **48** through the intake grid **100**. The air is discharged through two spaced openings in the scroll housing **48**. A first opening **51** seen in FIG. 3A, is in the front of the scroll housing **48**. The air discharged from opening **51** flows directly into the opening **25** into air flow channel **26**. From channel **26**, the air is discharged from an outlet opening **35** between the inner and outer shell portions **18** and **20**, respectively, in the front of the shell **17**.

The second opening, opening **53**, is located in the rear of the scroll housing **48**, best seen in FIG. 3B. The air discharged from opening **53** flows into a manifold mounted to the rear of the scroll housing **48**. From the manifold, the air is discharged from two downwardly directed nozzles. The manifold and nozzles are formed as a single unit, S in FIG. 3. When the system **10** is worn, the nozzle discharge ports are positioned adjacent the back of the neck of the wearer.

The air flow channel **26** defined between the inner and outer shell portions **18**, **20** terminates at the front section **34** with the front air exits. More specifically, the inner and outer shell portions **18**, **20** converge toward the front section **34** to define the front air exits. The front air exits may have an air deflector defined between the outer shell portion **20** and the inner shell portion **18** wherein the outer shell portion **20** angles toward the inner shell portion **18** at the front air exits for proper deflection of air toward the front of the head **14** of the user. Such an air deflector is best shown in U.S. Pat. No. 6,481,019 et al., which, again, is hereby incorporated by reference. Air flow channel **26** diverges upon approaching the front air exits. The convergence and divergence of the air flow channel **26** maintains a balanced flow of air about the user's head **14**. Ultimately, this also has the effect of minimizing or even completely eliminating noise within the helmet assembly **12** due to the air flow.

Referring to FIGS. 2, 3, 4 and 8, an adjustable head band **128** assists in minimizing the strain on the head **14** and the neck of the user. Strain and torque on the head **14** and neck of the user is minimized by maintaining the weight of the fan **50** and motor **52** over the neck of the user even upon adjustment of the helmet assembly **12** to fit various sized heads **14**. The head band **128** includes a rear support **130** that rigidly extends from the shell **17**. It is understood that the rear support **130** can be a separate part that is connected to the helmet assembly **12** or can be an integral part of the helmet assembly **12**. The rear support **130** includes first and second rigid connectors **132** that connect the rear support **130** to the rear section **36**. In the preferred embodiment, the rear support **130** is connected to and extends from the rear section **36** of the inner shell portion **18** and will be described below in terms of the inner shell portion **18**. However, it is to be understood that the rear support **130** can connect to and extend from any portion of the shell **17**.

An adjustment segment **134** having a first side **136** and a second side **138** is also part of head band **128**. Although not required, the rear support **130** preferably includes the adjustment segment **134**. In the preferred embodiment, the adjustment segment **134** is integral to, or the same part as, the rear support **130**. In alternative embodiments, the adjustment segment **134** is a discrete component that is simply mounted to the rear support **130**. In either situation, the adjustment segment **134** defines apertures **140** for receiving a first end **144**

and a second end **146** of a strap **142** flexibly connected to and extending from the front section **34** of the inner shell portion **18**. The first end **144** is disposed within the first side **136** of the adjustment segment **134**, and the second end **146** is disposed within the second side **138** of the adjustment segment **134**. Preferably, the first end **144** is movably disposed within the first side **136** of the adjustment segment **134**, and preferably the second end **146** is movably disposed within the second side **138** of the adjustment segment **134**. However, as will be understood from the explanation below, the first end **144** may be movably disposed within the first side **136** of the adjustment segment **134** and the second end **146** may be fixedly disposed within the second side **138** of the adjustment segment **134**. Alternatively, the first end **144** may be fixedly disposed within the first side **136** of the adjustment segment **134** and the second end **146** may be movably disposed within the second side **138** of the adjustment segment **134**.

The strap **142** further includes a frontal portion **148** disposed between its first and second ends **144**, **146** and opposite the adjustment segment **134** of the rear support **130**. At least one support arm **150** flexibly extends from the frontal portion **148** of the strap **142** to flexibly connect the strap **142** to the front section **34** of the inner shell portion **18**. These support arms **150** act as hinges for the head **14** support assembly. Preferably, there are two support arms **150** that extend from the frontal portion **148** of the strap **142**. In such a case, the two support arms are connected to the front section **34** of the inner shell portion **18** and to the frontal portion **148** of the strap **142** equidistant from one another. A gap **152** exists between the frontal portion **148** of the strap **142** and the front section **34** of the inner shell portion **18**.

III. Toga and Hood

Referring to FIG. 5, the personal protection system **10** includes a toga **88** having a body portion **90** for covering substantially all of the body **16**. Toga **92** includes a hood **92** for covering the head and helmet assembly **12**. The body portion **90** can extend downward to cover any portion of the body **16** of the user. For instance, the body portion **90** can extend downward to the waist of the user, or to the ankles of the user. The hood **92** includes a filter element **94** to filter air between the user and the external environment. The facial section **40** of the helmet assembly **12**, introduced above, also operates to maintain the hood **92** away from the head **14** of the user. The intake grid **100** spaces the filter medium **94** out away from the outer shell portion **20** and the fan **50**.

As is known in the art, a hood unit may be offered as a covering separate from the complete toga. This type of hood unit is used when there is only a need to provide a barrier around the head of the wearer.

A transparent face shield **96** permits the user to view through the hood **92**. The face shield **96** may include anti-reflective and/or anti-refractive coatings to enhance vision through the face shield **96**. As shown in FIG. 5, the face shield **96** is mounted to the hood **92** such that the face shield **96** covers the facial section **40** and the facial opening **42** of the helmet assembly **12** once the user dresses into the personal protection system **10**. The face shield **96** is sewn into the hood **92**. The facial opening **42** of the helmet assembly **12** receives the face shield **96**. In this version of the invention, facial section **40** of the helmet assembly **12** includes a hook-and-loop fastener to further facilitate attachment of the face shield **96** to the facial section **40** for covering the facial opening **42**.
IV. Light Assembly and Fan Assembly

As shown in FIG. 3 and FIGS. 7-19, the personal protection system **10** includes a light assembly **200**. The light assembly **200** is disposed within the hood **92** behind the face shield **96** to emit a beam of light that projects outside of the hood **92**.

Since the light assembly is disposed within the hood **92**, there is no need to meticulously clean the light assembly to keep it to the sterile conditions of a surgical room. Light assembly **200** includes a light generating unit, light source **201**, disposed adjacent to a lens (not shown).

The light source is preferably one or more light-emitting diodes (LEDs). The LED emits white light. In one version of the invention, light is emitted at a color temperature of 5500° K. Light in this spectrum is equivalent to daylight and provides true tissue color rendition. A light housing **202** supports and surrounds the LEDs and the lens. One suitable light assembly **200** is the PeriLux LED, manufactured by PeriOptix, Inc. of Mission Viejo, Calif. The light source may alternatively be an incandescent light bulb or other suitable sources as are well known in the art. One possible alternative is the use of a light source mounted somewhere on the user and fiber-optic cables to carry the light to the light housing.

The lens is circular in shape. In some versions of the invention, the longitudinal position of the lens relative to the light source **201** is selectively set. This allows the user to selectively focus/diffuse the beam of light emitted from the light assembly **200**. Many lens displacement assemblies include a rotating collar. Rotating the collar in a first direction cause movement of the lens to focus light is concentrated in a small area. Rotation of the collar in the opposite direction results in movement of the lens so that the emitted light is diffused about a large area. This rotation of the collar may be done manually or with a focusing servo motor. Control of the electric servo motor is explained in greater detail below.

Light assembly **200** includes a light angle adjustment mechanism **204**. Mechanism **204** allows the user to change the direction of the beam of light so it can be directed to a specific location. Specifically, the light housing **202** is pivotally mounted to two parallel legs **210** (one shown in FIG. 7). Legs **210** are integrally formed with and extend downwardly from a rigid block **209**. Block **209** is attached to the front outer surface of the strap **142**. A pin **211** that extends through the ends of the legs **210** pivotally holds the light housing **202** to the legs.

A semi-rigid cable **216** regulates the pivotal movement of the light housing **202**. The cable **216** is contained in a sheath (not identified). A cable clamp AW and rivet P cooperate to hold the forward end of the sheath to the exposed face of the inner shell portion **18**. The rear end of the sheath, with the cable **216** contained therein, extends through an opening in the shell **17** into the void space between the inner and outer shell portions **18** and **20**, respectively. A ring clamp AZ is disposed over the front of the housing, immediately proximal to the front face. The opposed ends of the ring clamp (one shown as element **206** in FIG. 8) extend upwardly towards shell **17**. An elongated screw **217** (FIG. 3) extends between ring clamp ends **206** to compression secure the ring clamp AZ to the light housing **202**. The front end of the cable **216** is wrapped around the exposed section of screw BA between the ring clamp end sections **206**.

As seen in FIG. 10, a lever arm **214** disposed inside shell **17**, selectively extends and retracts the cable **216**. Lever arm **214** is connected by a pin (not identified) to an adjustment knob **212** located outside of the shell **17** (FIG. 9). The pin extends through the shell outer portion. The proximal end, the rear end of the cable **216** is attached to the end of the lever arm **214** distal from the pin. The rotation of the knob and lever arm sub-assembly thus results in the extension/retraction of the cable. The cable movement, in turn pivots the light housing **202** around the axis defined by pin **211**.

The light housing **202** and, more particularly, the light source **201**, are positioned directly under the front air outlet

opening **35**. By positioning as such, the air discharged from opening **35** blows the warm air surrounding the light assembly **200** away from the light assembly. This reduces the build up of heated air adjacent the light assembly. Instead, the heated air is exhausted out of the hood **92**. The removal of this heated air lessens the extent to which the heat generated by the light assembly excessively warms the wearer of the personal protection system **10**.

Still another feature of this construction of the invention is that it minimizes the extent to which the temperature of the light assembly **200** itself rises due to the heat emitted by source **201**. By maintaining the light source **201** at a relatively low temperature, the source itself is able to function as a relatively efficient light emitter. (The light-emitting efficiency of LED type light source drops with an increase in the temperature of the LED.)

Referring now to FIG. 20, the control circuit for motor **52** and light source **201** are shown in block form. Power supply **70** energizes both the motor and the light source. In alternative versions of the invention, power supply **70** may be divided into a pair of power supplies, with each power supply individually powering the motor **52** or the light assembly **200**.

Power supply **70** is preferably at least one cell (i.e., battery). The at least one cell may be rechargeable. However, non-rechargeable (i.e., disposable) cells may also be used. In one version of the invention, power supply **70** provides a 6 VDC power signal. However, other voltages may alternatively be implemented.

The first power supply **70** is preferably mounted to the body **16** of the user as shown in FIG. 5. By mounting the first power supply **70** outside of the toga **88**, it can be easily replaced (i.e., switched out) during a medical/surgical procedure. In some versions of the invention, power supply **70** is located where it is accessible through the toga. Alternatively, the first power supply **70** may be disposed within, i.e., integrated into, the helmet assembly **12**.

Referring again to FIG. 21, the personal protection system **10** further includes a fan control circuit **224** for regulating the actuation of the fan motor **52**. A voltage regulator **220** applies a constant voltage signal to control circuit **224** for energizing the control circuit. Voltage regulator **220** regulates the 6 VDC electric current received from the power supply. In one version of the invention, voltage regulator **220** provides a 3.3 VDC electric current which energizes the fan control circuit **224**.

A light control circuit selectively applies an energization signal to the light source **201** to control both the on/off state of the light source and the intensity of the light emitted by the source. In FIG. 21, the light control circuit is shown as current regulator **230**. The current regulator **230** receives a constant voltage energization signal from a voltage regulator **222**. In one version of the invention, voltage regulator **222**, which is connected to power supply **70**, supplies a 3.6 VDC signal to current regulator **230**.

In some versions of the invention a single voltage regulator provides a common constant voltage to both the fan control circuit and the light control circuit. In some versions of the invention, there may not even be a need to provide a voltage regulated energization signal to either the fan control circuit or the light control circuit. Thus, in some versions of the invention, either one or both of the fan and light control circuits are powered directly from the power supply **70**.

The fan control circuit **224** is electrically connected to the fan motor voltage regulator **220** and the motor **52**. The fan control circuit **224** receives electric current from the fan motor voltage regulator **220** and conditions the electric current to control the speed of the motor **52** and the fan **50**.

In the illustrated version of the invention, the fan control circuit **224** provides implements pulse-width modulation (PWM) for controlling the speed of the motor **52** and the fan **50**. To accomplish the PWM, the fan control circuit **224** includes a microcontroller **118** and a power transistor **226**. The microcontroller **118** includes a plurality of inputs and outputs. Two switches **120** and **122** are pushbuttons are electrically connected to individual inputs of the microcontroller **118**. (Not identified are the pull up resistors associated with the switches.) The user presses the pushbuttons to adjust the desired speed of the fan **50** (and the consequential air flow). The switches are in the form of pushbuttons mounted to the side of the helmet assembly **12** and are easily operable by the user through the hood **92**.

At least one output of the microcontroller **118** is electrically connected to the power transistor **226** to selectively turn on and turn off the transistor based on the desired speed of the fan **50**. More specifically, the energization signal applied through the transistor is a PWM signal having a constant frequency and a variable on duty cycle that is directly proportional to the desired fan speed.

Power transistor **226** is in one version of the invention, actually a pair of power MOSFETs, the individual MOSFETs not shown. Here a primary MOSFET is a P-channel type and a secondary MOSFET is an N-channel type. The drain of the primary MOSFET is tied to the positive input of the power supply. The source of the primary MOSFET is tied to fan motor **52**. The gate of the primary MOSFET is tied to the positive terminal of the battery through a resistor. The drain of the secondary MOSFET is also tied to the gate of the primary MOSFET. The source of the secondary MOSFET is tied to ground. The gate of the secondary MOSFET is connected to a control line from the microcontroller **118**. Thus, the signal present at the drain of the secondary MOSFET gates the primary MOSFET. The IRF7307TR Power MOSFET manufactured by International Rectifier, headquartered in El Segundo, Calif. is a single package that contains both the P- and N-channel MOSFETs that collectively form power transistor **226**. Of course, those skilled in the art realize other possible implementations of the power transistor **226** are possible.

Microcontroller **118** is preferably is a Model ATmega8 manufactured by Atmel Corporation, headquartered in San Jose, Calif. The ATmega8 includes built-in PWM support. Other suitable microcontrollers **118** or microprocessors are evident to those skilled in the art. The microcontroller **118** may also be used for functions separate from controlling the speed of the fan **50**, as is described in greater detail below.

In one version of the invention, the current through motor **52** is used as feedback signal to establish the PWM rate. A resistor (not illustrated) is tied between the motor **52** and ground. The voltage across the resistor is applied to microcontroller **118** so as to serve as an indication on the motor speed. Motor speed is adjusted by varying the percent on duty cycle of the pulse per fixed total period (on and off) of the pulse.

Microcontroller **118** may also be electrically connected to the focusing servo motor and the light angle servo motor. This eliminates the need to hand adjust the light.

In addition to controlling the volume of air flowing into the helmet assembly **12**, the invention provides an audible indication of when the fan is at the minimum and a maximum air flow rates. This indication is provided by momentarily resetting the frequency of the PWM signal applied to the motor. This in turn, causes the motor to be actuated at a rate that causes is shaft to rotate in a manner that causes sound detectable by the human ear to be emitted. This sound provides an audible indication of the minimum and the maximum volume

of air to the user. That is, the present invention provides the user with an audible 'ping' upon reaching the minimum and maximum volumes of air flowing into the helmet assembly **12**.

This ping is also provided each time the control circuit **224**, in response to the depression of one of the control buttons, raises or lowers the speed of the fan motor **52**. At the opposed high and low ends of the motor speeds, the controller is configured to actuate the motor so two closely spaced apart in time pings are emitted at the same frequency. This provides the user notice the maximum or minimum motor speed setting has been reached.

The audible ping is provided by, for a brief period, for example between 0.1 and 0.2 seconds, running the fan motor at a frequency at which the motor generates an audible sound. For example, during normal actuation of the motor, the constant frequency of the energization signal applied by the control circuit **224** is 30.3 kHz. Between the transition from outputting the energization signal at a first duty cycle to a second duty cycle, (in order to change the speed of the motor), the energization pulses are applied to the motor at a frequency of between 261 to 523 Hz at a 50% duty cycle. As a result of the energization pulses being applied at this frequency, the speed of the motor drops appreciably. This causes the motor **52** to emit a tone detectable by the human ear.

In some versions of the invention, the frequency at which the motor is actuated in order to generate the ping varies with new speed range the motor is being set to operate at. For example, in one embodiment of this version of the invention, prior to each time the control circuit **224** increases the on duty cycle of the motor energization signal in order to increase motor speed, the control circuit first applies a high frequency ping-generating energization signal. This results in a relative high frequency ping signal being generated. Prior to the control circuit **224** decreasing the on duty cycle for the energization signal in order to decrease motor speed, the control circuit applies a lower frequency ping-generating energization signal. This results in the emission of a lower frequency ping from the motor **52**. Thus, the surgical personnel not only receive an audible indication the fan speed is being reset, they receive an indication regarding if the speed is being lowered or increased.

However, it is to be understood that the frequency at which the motor is selectively actuated may otherwise be within the acceptable range of unaided human hearing (30 Hz to 20 kHz) so long as it provides the audible indication. The frequency of the activation rate causes various components of the motor **52** of the fan module **46** to vibrate at the frequency thereby generating the audible indication.

Alternatively, the fan control circuit **224** includes a potentiometer, also commonly referred to as a variable resistor or varistor, to control the speed of the motor **52** and fan **50**, instead of utilizing PWM. Additional implementations for varying the speed of the motor **52** and fan **50** are known to those skilled in the art and may be alternatively utilized.

A printed circuit board **228** (PCB) is disposed within the helmet assembly **12**. The PCB **228** supports the voltage regulators **220**, **222**, the microcontroller **118**, and associated electronic devices. The PCB **228** includes conductive tracks to electrically connect items mounted on the PCB **228**, as is well known to those skilled in the art.

The personal protection system **10** also includes a light current regulator **230** for providing a constant current, regardless of voltage, to the light source. By keeping the current constant, the light source provides a steady illumination that does not degrade as the cells of the first power supply **70** drain and lose voltage. The light current regulator **230** is preferably

integrated with the light assembly **200** within the light housing. However, the light current regulator **230** may be disposed on the PCB **228**.

The personal protection system **10** also includes a low power detection circuit for alerting the user when the cells of power supply **70** are running low. In the preferred embodiment, a voltage divider circuit **232** comprising a pair of resistors is electrically connected to the first power supply **70**. The signal present at the junction of the resistors is applied as an input signal to microcontroller **118**. An enunciator **234** is electrically connected to one of the outputs of the microcontroller **118**. The enunciator **234** may be an indicating LED, preferably mounted within the helmet assembly **12** and within the field of view of the user. The enunciator **234** may also be a loudspeaker for producing an audible signal that is bearable by the user, or a combination of the loudspeaker and LED. Alternatively, the enunciator **234** may be substituted with selectively activating and deactivating the power transistor **226** to vibrate the fan and generate an audible signal, as described above.

V. Communications Unit

Referring to FIGS. **22-27**, personal protection system **10** also includes a communications unit **236**. The communications unit **236** provides wireless communication between other communications units **236**. The other communication units may be integrated with other personal protection systems **10** or embodied as one or more stand-alone units. The communications units **236** allow for convenient voice communications between the users of the personal protection systems **10**.

The communications unit **236** includes a microphone **238**, a speaker **240**, and a transceiver **242**. Communications unit **236** also includes a second power supply **244**. The second power supply **244** powers transceiver **242**. Second power supply **244** is preferably at least one cell. The at least one cell is preferably rechargeable; however, non-rechargeable cells may also be used. The at least one cell may be a single cell or a plurality of cells connected together. The transceiver **242** and second power supply **244** are often packaged together and mountable on the body **16** of the user.

Alternatively, as seen in FIG. **26**, the transceiver **242** is electrically connected to the first power supply **70**, such that the user would not have to carry multiple power supplies. In these versions of the invention a third voltage regulator **241** provides a third constant voltage signal to the transceiver **242**. This third voltage is different from the regulated voltages provided to the fan control circuit **224** and the light control circuit (current regulator **230**). Transceiver **242** may also be alternatively disposed within the helmet assembly **12**.

Microphone **238** converts speech into electrical signals. The signals produced by the microphone **238** are applied to the transceiver **242**. Transceiver **242** is preferably a radio frequency (RF) transceiver **242** capable of transmitting and receiving RF signals. The transceiver **242** converts the electrical signal into an RF signal and transmits the RF signal. The transmitted RF signal may then be received by the transceivers **242** of the other communication units. The transceiver **242** converts the received RF signal into an electrical signal. The speaker **240** is electrically connected to the transceiver **242** and receives the electrical signal from the transceiver **242**. The speaker **240** decodes the electrical signal into an audio wave which can be heard by the user.

Microphone **238** is attached to the chin bar **44** of the helmet assembly **12**. A cable **239** (shown in phantom) over which the signals produced by the microphone is similarly disposed in the chin bar **44**. The microphone may be mounted to other locations on the helmet.

In one version of the invention, speaker **240** is an earpiece. The earpiece includes a hook shaped to be worn on the ear of the user. A bud with the actual sound generating transducer is attached to the hook. The bud is shaped to be positioned adjacent or in the ear canal of the user. The audio signal cable that supply signals to the bud are mounted to the helmet. The front end of the cable is however, not mounted to the helmet. This provides a degree of flexibility between the earpiece and the helmet shell **17**. This flexibility accommodates for differences in body size of individual users. This flexibility also allows the user to move his/her head while using the personal protection system **10** of the invention while the earpiece remains in place. Also, multiple mounting assemblies are provided in the helmet. This allows the earpiece to be mounted for insertion in either ear of the user of the system **10**.

Transceivers **242**, in one version of the invention, operate in the 900 MHz band. The individual transceivers exchange digital, spread spectrum RF signals. The communications units **236** preferably operate in full duplex, i.e., the transceivers **242** can transmit and receive RF signals at the same time. One example of a suitable transceiver **242** is the STx 1000 manufactured by Eartec of Narragansett, R.I. Coachcomm of Auburn, Ala. also markets an appropriate transceiver system. Each of these systems allows three or more individuals to simultaneously use the surgical protect system **10** of this invention and communicate in full duplex mode with each other using the transceivers. There is no need to depress a push-to-talk switch in order for any individual to communicate with another individual. Thus, this protection system **10** allows a group of individuals (three or more) to engage in conversation with each other as if in normal group conversation, without having to raise their voices in order to overcome the sound attenuating of the protective hoods **92** and the noise generated by the fan **50** and motor **52**.

FIG. **27** illustrates in block form an alternative transceiver **242a** of this invention. Transceiver **242a** includes a modulator **252** for converting audio signals received from the microphone **238** into RF signals. The RF signals generated by the modulator **252** are broadcast over communications unit antenna **237**. Also connected to antenna **237** is the transceiver demodulator **254**. The demodulator **254** converts the received RF signals into audio signals that can be used to actuate the speaker **240**.

Actuation of the modulator **252** and demodulator **254** is controlled by a transceiver controller **256** also part of transceiver **242a**. This transceiver controller **256** could be a conventional digital microprocessor, a PLA or a DSP. Transceiver controller **256** regulates the actuation of the modulator **252** and demodulator **254** in part based on the state of three user actuated switches **258**, **260** and **262**. An individual wearing system **10** of this invention could actuate one switch, for example switch **258**, in order to effectively "turn off" the demodulator **254**. An individual takes this step if he/she does not want to receive the transmissions broadcast by others employing the communications units. If the individual wants the transceiver **242a** in this state, the transmitter controller could respond by deactivating the demodulator **254**. Alternatively, the transceiver controller **256**, in response to the user wanting speaker **240** deactivated, turns on a FET that causes the audio output signal generated by the demodulator **254** to go to ground (FET not illustrated).

Transceiver controller **256** also selectively deactivates the output of RF signals by the modulator **252**. The individual using system **10** may want the modulator **252** to temporarily stop broadcasting RF signals with embedded audio signals if he/she wants to conduct a conversation with a nearby indi-

vidual that is not for broadcast. Switch **260** is actuated to regulate the selective broadcast of the RF modulated audio signals. In response to the individual wanting the transceiver **242a** to not broadcast audio signals, the transceiver controller **256** temporarily stops actuation of the modulator **252**. Alternatively, by switching a FET (not illustrated) the transceiver controller **256** selectively blocks the forwarding of audio signals from the microphone to the modulator **252**.

The transceiver controller **256** also regulates the modulator **252** to control which group or groups of other communication units **236** are able to receive signals emitted by the transceiver **242a**. For example, in versions of the invention wherein the individual transceivers exchange signals using a direct sequence spread spectrum protocol, the transmitter controller **256** regulates the codes used to establish the modulation of the output signals and the demodulation of the input signals. In versions of the invention wherein the individual transceivers exchange signals using a frequency hopping spread spectrum protocol, transceiver controller **256** generates the code that establishes the frequency hopping pattern of the carrier frequency. Switch **262** is the control member that is actuated to establish which group or group of communications units are able to exchange and/or receive signals.

The utility of the protection system of this invention's ability to selective exchange signals is now explained by reference to FIG. **28**. Here, five individual communication units **236a-236e** are shown. Arbitrarily, communications unit **236d** is one unit that has this selective transmission/reception capability. Thus, by depressing switch **262**, the associated transmitter controller **256** configures the transceiver **242a** of communication unit **236d** so that the broadcast audio signals can be received by all the remaining units **236a**, **236b**, **236c** and **236e** or just by unit **236e**. This allows a surgeon to have some privacy to communication with another individual wearing the system **10**. Alternatively, this allows a surgical assistant to communicate with another individual without disturbing the surgeon.

In FIG. **29**, a receiver **264** is also shown. The receiver is capable of receiving the signals broadcast by one or more of the communication units **236a-236e**. The audio signals broadcast by the receiver **264** can be broadcast through a loudspeaker **263**. This may be desirable in a teaching setting. Alternatively, the audio signals may be stored with the aid of a recorder **265**. Again, by selective modulation of the broadcast signals, the ability of the receiver to demodulate the signals broadcast by any particular transceiver **242a** is selectively regulated.

Returning to FIG. **28**, it is seen that a unit processor **272** is connected to the transceiver controller **256**. Digital signals extracted from the received RF signals by the demodulator **254** are forwarded to the transceiver controller **256**. Modulator **252** is able to embed digital signals received from the transceiver controller **256** into the broadcast RF signals. Primarily the transceiver controller **256** functions as an intermediate processor for transmitting digital signals received by the unit processor **272** and forwarding digital signals used by the unit processor. In some versions of the invention, transceiver controller **256** and unit processor **272** are a single unit.

The digital RF signals are exchanged with a static RF transceiver **259** seen in FIG. **28**. Transceiver **259** is connected to a communications bus **266** in the operating room. Other units connected to the bus include the below-discussed operating room control head **261** and equipment such as a personal computer **268**. One such operating room control head **261** is sold by the Applicants' Assignee under the trademark SIDNE. This arrangement allows the transceiver **242a** to serve as the unit through which other components of the

surgical protection system **10** exchange signals with remote devices. In FIG. **28**, the operating room control head is shown as receiving audio signals from the static receiver **264**. In some versions of the invention, transceivers **264** and **259** are a single unit.

For example, by speaking into the microphone **238**, the surgeon speaks the command "Focus Light". The audio signal representative of these words is transmitted by transceiver **242a** to the operating room control head. The operating room control head processes the audio signals to decode the command. Once the command is interpreted, the operating room control head, through transceiver **259** generates a command data packet to the transceiver **242a**. The transceiver **242a** strips out the command message and forwards it to the unit processor **272**. Unit processor **272**, upon receipt of the command, generates appropriate control signals to cause the actuation of the servo motor employed to displace the lens integral with the light assembly **200**.

The speed of the fan motor **52** is similarly regulated by the integrated system of this invention.

Communication unit **236a** can also provides voice actuated control of the other equipment in the operating room such as the surgical instruments and the operating room environmental settings (HVAC and light). More specifically, the spoken commands entered through microphone **238** are transmitted by transceiver **242a** and receiver **264** to the operating room control head **261**. The operating room control head then generates the appropriate instruction packets that are output on bus **266** to the appropriate device that is to act on the instructions.

The integrated construction of the system of this invention also allows the personal protection system **10** to report back information regarding its own operating state. In FIG. **28**, the signal present at the junction of the two resistors forming voltage divider **232** is shown as being applied to unit processor **272**. In the event the signal present at this point falls to a level at which indicates the charge stored in power supply **70** is becoming low, the unit processor **272** generates a data packet with these data. The data packet is forwarded to the transceiver controller **256** so it is broadcast by the transceiver **242a**. The data packet is received by transceiver **259**. This packet is forwarded to the personal computer **268**. This provides personnel in the operating room with notice that the particular power supply **70** worn by a specific individual is close to being discharged and should be replaced.

VI. Alternative Head Unit

FIGS. **29** through **34** illustrate an alternative support structure for supporting hood **92** around the head and upper body of the wearer. This particular support structure is a head unit **270**. Head unit **270** includes a head band **272** to which a ventilation unit **274** and light **276** (FIG. **49**) are adjustably mounted. The air forced through the ventilation unit **274** is discharged through front and rear nozzle assemblies **280** and **282**, respectively. The adjustability of the ventilation unit **274** relative to the head band allows the components forming the unit, primarily the ventilation fan **278**, to be positioned relative to the body of the wearer where the physical strain the unit imposes on the wearer is minimized.

More particularly, head unit **270** includes a face frame **286** formed of plastic that has some flexibility. In one version of the invention, face frame **286** is formed from polypropylene or Nylon. Face frame **286**, best seen in FIG. **35**, is shaped to have a forehead band **288** that has a curvature designed to allow the bar to fit against the forehead of the individual. Not shown are padding that may be secured to the inner surface of the forehead band **288**. Extending downwardly from the opposed ends of forehead band **288**, face frame **286** has

downwardly extending support posts **290**. A chin bar **292**, also part of face frame **286** extends between the opposed bottom ends of support posts **290**. Chin bar **292** has a curved shape such that forward portion of the guard between the posts **290** extends forward of the posts.

Also part of face frame **286** is a support strap **294**. Support strap **294** is in the form of a generally rectangular strip and extends upwardly from the center of the forehead band **288**. As discussed below, support strap **294** is the member from which the ventilation unit **274**, light **276** and front nozzle assembly **280** are suspended. Given that the face frame **286** is formed from flexible material, it should be appreciated that strap **294** has some degree of flexibility, can move angularly relative to forehead band **288**.

A mounting pin **296** extends outwardly from each of the face frame support posts **290**. Each mounting pin **296** has a stem (not identified) that extends outwardly from the outer surface of the associated support post **290**. Each mounting pin **296** also has a wide diameter head **298** that forms the free end of the pin. Mounting pins **296** support and secure the transparent shield integral with the hood.

A head strap **302** extends rearwardly from each end of the face frame forehead band **288**. Collectively, the forehead band **288** and head straps **302** form the head band **272**. Head straps **302** are formed from very flexible plastic such as Nylon **66**. Each head strap **302**, as seen in FIG. **36**, includes a base **306** that has a relatively wide width. Base **306** is seated against the inner surface of the associated end of the forehead band **288**. Two openings **308** extend through each strap base **306**. Openings **308** accommodate fasteners (not illustrated,) that hold the head strap **304** to the face frame **286**. In the illustrated versions of the invention, a counterbore (not identified) extends around each opening **308**.

A leg **310** extends downwardly from the each head strap base **306**. Each leg **310** has a width less than that of base **306** from which the leg extends. Each head strap **302** has a rack **312** that extends from the free end of the leg **310**. The racks have a set of teeth (not identified) that extend laterally away from the longitudinal axis of the rack. FIG. **36** illustrates the head strap **302** for the left side of head unit **270**. This head strap **302** is formed so that the rack teeth project downwardly. The head strap **302** for the right side of the head unit **270** is formed so that the teeth project upwardly. A toe **314** projects perpendicularly away from the free end of each rack **312**. Each toe **314** is directed in the same direction in which the associated rack teeth are directed.

Rear nozzle assembly **282** both directs the output flow from the fan **278** down the neck of the wearer and holds head straps **302** together. Rear nozzle assembly **282** includes a shell **320** and a tip **318** that rotates around the longitudinal axis of the shell.

The rear nozzle assembly shell **320** now described by reference to FIGS. **37** and **38**. Shell **320**, is formed from a single piece of plastic and has a three-sided trunk **322** from which two wings **324** extend. More particularly, the trunk **322** is formed to have a back wall **326** that curves into two opposed side walls **328**. Shell **320** is further formed so that the opposed side walls **328** are inwardly tapered. Consequently, shell **320** is wider at the top than at the bottom. The shell **320** is further formed to have two spaced apart ribs **330** and **332** that extend laterally across the inner surface of the shell, from side wall to side wall. Rib **330** is located around the open end of the shell **320**. Rib **332** is parallel to and located below rib **330**.

A plate **334** extends from the inner surfaces of back wall **326** and side walls **328**. Plate **334** extends to and does not project beyond the inner edges of the side walls **328**. An opening **336** extends through the plate **334**. Opening **336** is

centered along an axis that extends longitudinally through the void space defined by the shell back wall **326** and side walls **328**.

A rigid tubular sleeve **340** extends inwardly from the shell back wall **326** so to project into the void space between the back wall and side walls **328**. Sleeve **340** extends from an opening **342** in the back wall **326**. The back wall **326** is further formed to have an annular ring **344** concentric from and radially spaced away from opening **342** that projects from the wall outer surface. Ring **344** is formed with spaced apart teeth **346** that extend inwardly to opening **342**.

Each shell wing **324** extends from a separate one of the base side walls **328**. The wings **324** are basically three wall structures that are arranged so that the open faces thereof extend forwardly, toward face frame **286**. Plural spaced apart reinforcing webs **350** extend through the void spaces defined by each wing **324** and the trunk side wall **328** from which the wing extends. Webs **350** extend laterally, that is perpendicular to the top-to-bottom longitudinal axis through the shell **320**.

A plate **352**, also part of the rear nozzle assembly **282**, extends over the open void defined by the shell **320**. Plate **352**, now described by reference to FIG. **39**, has a panel section **354** with a generally concavo-convex profile. The panel section **354** is further formed to have side edges (not identified) that are inwardly tapered. Panel section **354** is further formed so that the opposed top and bottom side edges are outwardly bowed. The panel section **354** is also shaped to have curved corners.

Extending outwardly from the inner surface of the panel section **354**, the surface seen in FIG. **39**, plate **352** is shaped to have two four sided reinforcing frames **356**. Each reinforcing frame **356** extends outwardly from the inner surface of panel section **354**. Each frame **356** has two parallel and spaced apart top and bottom ribs **358**. An outer rib **360** located along the adjacent side edge of the panel section **354** extends between ribs **358** at one end of each frame. An inner rib **362**, that is curved toward the side, extends between each of the ribs at the opposed inner end of each frame **356**.

A hole **364** extends through the center of panel section **354**. The panel section **354** is formed with an annular rib **366** around the hole **364**. The plate **352** is further shaped so that the frame inner ribs **362** have a center of curvature that is concentric with hole **364**.

A foot **368** projects outwardly from the bottom of panel section **354**. Foot **368** has a planar base **369** that forms the bottommost structural component of the plate **352**. Steps **370** extend from the opposed ends of foot **369** to the adjacent sections of the panel section bottom edge. Short lips **372** extend from each step **370** a short distance along the adjacent section of the panel section bottom edge. A reinforcing web **374** extends along the inner surface of the panel section **354**. Web **374** extends between the opposed free ends of lips **372**. The web **374** is parallel with and spaced apart from the two linearly aligned bottom ribs **358** of the reinforcing frames **356**. Thus, a slot **359** is defined between the lowermost ribs **356** and web **374**.

The plate **352** also has a three sided collar **378** that is integral with and extends a short distance above the panel section **354**. Collar **378** has a front wall **380**. Two side walls **382** curve inwardly from the opposed ends of the front wall **380**. Formed integrally with the collar are two parallel ribs **384** and **386**. Rib **384** extends inwardly across the coplanar top edges of the collar front wall **380** and side walls **382**. Rib **386** is located below and is spaced from rib **384**.

A lip **387** extends from each collar outwardly along the panel section top edge. The lips **387** project away from the inner surface of the panel section **354**. A web **390** extends

17

outwardly from the inner surface of the panel section 354 between the ends of the opposed lips 387. The web 390 is parallel to and located above the opposed, linearly aligned top ribs 378 of the reinforcing frames 356. Thus, a slot 392 is defined by the top located ribs 356 and web 390.

Plate 352 is further formed to have a support arch 394. The arch 394, which has a generally circular shape, extends upwardly from top edge of panel section 354. While cross sectional slices through the arch are of constant diameter, the arch does not lie flat. The arch 394 is angled toward the center. This profile approximately matches the general contour at the back of the skull. More particularly, the opposed terminuses of arch 394 are each located between one end of collar 378 and the adjacent panel side edge. Arch 394 is flexible, can move angularly, relative to panel section 354. As discussed below, arch 394 flexibly supports the ventilation unit 274 above the head of the wearer.

When the rear nozzle assembly 280 is assembled, plate 352 is positioned against the open, forward directed surfaces of shell 320. A knob 396, also part of the rear nozzle assembly 282, is mounted to the exposed back surface of the shell 320. The knob 396, seen best in FIG. 40, includes a cylindrical shaft 398. Arcuately spaced apart teeth 402 extend radially outwardly along the shaft 398. The knob shaft 398 is further formed to have a bore 399 that is open from the free end of the shaft. In one version of the invention, bore 399 extends through a sleeve 401 constrict with and located in shaft 398.

The knob 396 also has a head 404 disposed over one end of the shaft 398. Internal to the head 404 is ring 406 that extends around the portion of the shaft disposed in the head. Ring 406 is concentric with and spaced radially outwardly from shaft 398. The ring 406 is formed with two diametrically opposed flexible tabs 408 (one shown). Each tab 408 has a single rib 410 that extends longitudinally along the outer surface of the tab.

The rear nozzle assembly 280 is constructed so that the knob shaft 398 seats in and extends through shell sleeve 340. The free end of the shaft 398 seats against the annular space about the reinforcing rib 366 formed in plate 352. A threaded fastener (not illustrated) extends through plate hole 364 and into bore 399 integral with knob 396. This fastener holds the panel 352 to the shell 320. When the rear nozzle assembly is so constructed, the ribs 410 integral with knob 396 seat in the void spaces between shell teeth 346.

When head unit 270 is assembled, the head strap racks 312 seat in the slots between shell 320 and panel 352. This is seen best in FIG. 30; here it is understood the left-right sides of head unit being inverted. Specifically, the rack 312 integral with the right side head strap 302 seats in slot 359. The rack 312 the forms part of the left side head strap seats in slot 392. The rack teeth engage knob teeth 402.

Rear nozzle tip 318, now described by FIG. 41, includes a tubular base 412. A lip 414 extends annularly around the open end of base 412 and away from the outer surface of base. Projecting upwardly from lip 414, nozzle tip 318 has four equangularly spaced apart mounting tabs 416. Each tab 416 has a head 418 with a tapered outer surface. When the rear nozzle assembly 282 is put together, tabs 342 snap fit in shell opening 336. Nozzle tip 318 is thus able to rotate relative to the axis that extends through opening 336.

Nozzle tip 318 is formed with a head 420 that partially surrounds the bottom open end of base 412. The nozzle tip 318 is formed so that tip head 420 is generally shell shaped such that the open end of base 338 opens into the void space defined by the concave surface of the head.

Returning to FIG. 34 it can be seen that ventilation unit 274 includes lower and upper shells 428 and 430, respectively,

18

that house a fan 433 and a motor 434. The lower shell 428, best seen in FIG. 42, includes a base 432. The lower shell 428 is formed so that the base 432 is widest at the center and relatively narrow at the opposed front and rear ends. Opposed side walls 434 extend upwardly from the side edges of base 432 extend along the longitudinal side edges of the base. Shell base 432 also has a cylindrical, hollow boss 436 that extends upwardly from the center of the base. Boss 436 is dimensioned to receive the fan motor 434. Not identified is the opening in the center of the boss 436 wherein the rotating shaft of the motor extends therethrough.

The lower shell 428 is formed with two pairs of posts 438 and 440 that receive fasteners for holding the upper and lower shells together. Each of the posts 438 and 440 extends upwardly from the shell base 432. A first pair of posts, posts 438, are located adjacent the front end of the lower shell 428. Each post 438 is located inwardly of an adjacent one of the side walls 434 at the front end of the shell 428. Each post 440 is located inwardly of and adjacent one of the side walls at the rear of the shell 428.

Two parallel ribs 442 and 444 extend inwardly from the shell base 432 and side wall 434 adjacent the rear opening these surfaces define. One rib, rib 442 extends inwardly around the open rear end of the shell. Rib 444 is located forward of and spaced apart from rib 442. While not illustrated, it should be appreciated that similar ribs project outwardly from the base 432 and side walls 434 at the front end of the lower shell 428.

The lower shell 428 also has a set of baffle plates 438 and 440 that partially surround and are radially spaced away from boss 436. One plate, plate 438, is generally S-shaped and starts at a locating slightly behind the open front end of the shell and the curves slightly inwardly. Baffle plate 438 then has a section that is has a radius of curvature that is centered on the axis of boss 436. This particular section of the baffle plate 438 subtends approximately 150° of the circumference around the boss 436. Baffle plate 438 also has a tail section that angles away from the S-section. This section of the baffle plate angles back to and abuts the adjacent shell side wall 434.

Baffle plate 440 has an arcuate profile. The baffle plate 440 extends from the side wall 434 opposite the side wall with which plate 438 is associated. Baffle plate 440 is spaced forward of and substantially covers the open end of the lower shell 428. The baffle plate 440 subtends an arc of approximately 70° around boss 436. There is an arcuate separation of approximately 5 to 10° between the arcuate section of baffle plate 438 and the adjacent plate 440.

The lower shell 428 is also formed so that there are a number of rectangular openings 442 in the base 432. Openings 442 facilitate the securing of a motor cover 444 (FIG. 34) to the exposed bottom surface of the lower shell 428 as discussed below.

The upper shell 430, now described by reference to FIG. 43, includes a lid 450 from which two side walls 452 extends. Lid 450 has a shape that generally conforms to that of lower shell base 432. The lid 450, like the lower shell base 432 is curved along its longitudinal axis. Side walls 452 extend along the longitudinal side edges of the lid and curve downwardly from the lid. The lid 450 is formed with a circular center opening 453. When the shells 428 and 430 are assembled together, opening 453 is coaxial with lower shell boss 436.

The upper shell 430 is further formed to have ribs 454, 456, 458 and 460 similar to the ribs 442 and 44 of the lower shell 428. Two parallel ribs 454 and 456 extend side wall to side wall at the front end of the upper shell. Rib 454 extends into the opening defined by the lid 450 and the adjacent side walls

452. Rib 456 is parallel to and spaced behind rib 454. Ribs 458 and 460 adjacent the rear opening of the upper shell 428 (ribs only partially shown.) The first rib, rib 458, extends around the rear opening. The second rib, rib 460, is spaced inwardly of rib 458.

Fan 433, illustrated in FIGS. 44 and 44A, has a circular base 462. A hollow boss 464 extends upwardly from the center of the base 462. While the fan base is circular, it is not flat. Instead the base 462 curves upwardly to the hole formed by boss 464. When the ventilation unit 274 is assembled, the fan 433 is fitted in the lower shell 428 for mounting to the motor 434 the fan boss 464 seats over shell boss 436. The motor shaft mounts to the center of the fan boss 464 (motor shaft securement means not illustrated.) Located around the outer perimeter of base 462 are a number of arcuately spaced apart blades 466.

A ring 468 is disposed over the top surfaces of the blades 466. While in cross section, ring 468 is flat, the ring has a tapered profile. Thus the inner edge of the ring is located above the outer edge. This change in lateral elevation of the ring 468 approximates the similar rise in elevation of the fan base 362. This profile of having these surfaces rise to the center approximates the curvature towards the center of the caudal portion of the skull. This is the portion of the head over which the ventilation unit 274 is centered.

A grill unit 470, also part of ventilation unit 274, is disposed over the top of the upper shell 430. As seen in FIG. 45, the grill unit 470 includes a frame 472. The frame 472 generally has a shape similar to that of the lid. However, frame 472 is sized to fit wholly on the outer surface of the upper shell lid 472. The frame, while formed from a set of flat strips of plastic, is shaped so that the strips are tapered inwardly. Thus the outer edges of the individual strips forming the frame are the surface of the grill unit 470 that seat against the adjacent outer surface of the upper shell lid 450.

Formed integrally with frame 472 is a lattice 474. The lattice is formed from a number of crossing webs. The lattice 474 extends over lid opening 453 and fan 433. Shown extending downwardly from frame 472 are snap tabs 473. When ventilation unit 274 is assembled snap tabs lock in openings 475 in the upper shell (FIG. 43) to hold the grill unit to the upper shell.

The motor cover 444, best seen in FIG. 46, is fitted to the exposed under surface of the lower shell base 432. Motor cover 444 has a main body 480 that, while sheet like in shape, is curved along its longitudinal axis. Motor cover main body 480 is also curved into the center of the longitudinal center axis. Again, this curvature approximates the curvature of the portion of the skull over which the ventilation unit is typically seated. The front end of the main body has a straight edge; the rear end has a curved profile between the side edges. The motor cover 478 is further formed to have a lip 482 that extends upwardly from the outer perimeter of the main body 480. More particularly, the lip 482 extends upwardly along the side and rear edges of the cover body 480.

Four feet 484 interrupt the lip 482. Each foot 484 is generally L-shaped and extends upwardly in the same direction as the lip 482. Each foot 484 extends from the cover main body 480. Two of the feet 484 are located immediately behind the front edge of the cover base 432. The remaining two feet 484 are located forward of the curved rear end. Each foot 484 has an outwardly extending toe 486. Toes 486 extend above the outer edges of the adjacent lip 482. Motor cover 444 is secured to the lower shell 428 by snap fitting toes 486 in shell openings 442.

Motor cover 444 is further formed so that, one each side, forward the rear end and rearward of the rear located feet 484, there is a gap 489 in the lip 482.

The motor cover main body 480 is formed with a slot 490 that extends along the longitudinal axis of the body. Slot 490 starts at the front end of the body. The slot 490 terminates at a location forward of the rear end of the main body 480. Immediately rearward of the front end of the main body 480, motor cover 444 is formed with two flexible fingers 492. The fingers 492 are located diametrically opposite each other relative to slot 490. The fingers 492 are formed integrally with the rest of the motor cover 444. Each finger 492 has a tip 494 that extends upwardly in the same direction as lip 482.

Ventilation unit 274 is partially suspended above the head of the wearer by arch 394. When head unit 270 is assembled, the upper end of the arch 394 is sandwiched between the outer surface of the lower shell 428 and the motor cover 444. Fasteners, (not illustrated,) hold the lower shell 428, and therefore the whole of the ventilation unit 274, to the arch. When motor cover 444 is secured to the lower shell 428 the arch extends through the gaps 489 in the cover lip 482.

An accordion-like rear bellows 498, seen in FIGS. 33 and 34, functions as the conduit from the rear end opening of the ventilation unit 270 to the rear nozzle assembly 282. At the ventilation unit end, rear bellows 498 extends through the generally oval shaped opening formed by the ends of the lower and upper shells 428 and 430, respectively. The forwardmost rib of the rear bellows 498 (rib not identified) is seated in the slot around this opening defined by adjacent lower shell ribs 442 and 444 the aligned adjacent upper shell ribs 458 and 460.

The rear end of rear bellows 498 seats in the oval opening defined by the adjoining top ends of the rear nozzle assembly shell trunk 322 and plate collar 378. The rear most rib of the rear bellows 498 is seated in the slot around this opening defined by shell ribs 330 and 332 and adjacent collar ribs 384 and 386.

Front nozzle assembly 280 includes a pedestal 502 and a cap 504. The pedestal 502, seen best in FIG. 47, includes a hollow post 506. Post 506 has a generally rectangular cross sectional profile. The base of the post 506 is secured to the section of the face frame support strap 294 immediately above the forehead band 288. Not shown are the fasteners used to accomplish this securement.

Above post 506, pedestal 502 has a head 508. The head has a planar base 510 that extends outwardly from the front, back and sides of the pedestal. Side walls 512 that curve upwardly from the opposed longitudinal sides of the base 510 complete the head 508. Two ribs 514 and 516 extend inwardly from the inner surfaces of the base 510 and side walls 512. Rib 514 is located around the rear end of the pedestal head 508. Rib 516 is parallel to and located forward of rib 514.

Cap 504 seats over the pedestal head 508 to complete the front nozzle assembly 280. Referring to FIG. 48, it can be seen that the cap 504 has a top panel 518 from which two side panels 520 curve downwardly (one side panel shown). The cap 504 is further formed so that the top panel 518 is curved along its longitudinal axis. When the front nozzle assembly 280 is put together, the cap side panels 520 abut the top edges of the pedestal head side walls 512.

The front nozzle assembly cap 504 is further shaped so that a rib 519 extends along the longitudinal axis of the cap top panel 514. The rib 519 is formed so as have slots 521 that extend inwardly from the sides (one slot shown.) At the front end of the top panel 518, a tab 524 extends upwardly. Tab 524 is thus located immediately in front of rib 519. A small web 525 extends perpendicularly from tab 524 to the rib 519.

21

Flange **525** extends upwardly from the longitudinal axis of the rib **519**. Immediately behind tab **524**, an elongated slot **523** is formed in the rib **519**.

While not illustrated, it should be appreciated that a pairs of ribs extend inwardly from the inner surface of the cap top panel **518** and side panels **520**. A first one of these ribs abuts pedestal rib **514**. The second cap rib abuts pedestal rib **516**.

A front bellows **528** seen best in FIGS. **31** and **34**, similar in structure to rear bellows **498**, serves as the conduit through which the forced air from the ventilation unit **274** is output to the front nozzle assembly **280**. The rear most rib internal to front bellows seats in the slot defined by lower shell ribs (not illustrated) and adjacent upper shell ribs **454** and **456**. The front most rib internal to the front bellows **528** seats in the slot defined by pedestal ribs **514** and **516** and the adjacent complementary ribs formed on the cap **504**.

Support strap **294** assists in the suspension of the ventilation unit **274** above the head of the wearer as now described by reference to FIGS. **29** and **31**. Specifically, when the support strap **294** extends through the open front end of the motor cover **444** below the lower shell **428**. Returning to FIG. **35**, it is noted that the support strap is formed with two rows of parallel openings **532**. Openings **532** extend laterally across the support strap **294**. The pairs of openings **532** are spaced apart from each other longitudinally along the length of the strap.

When support strap **294** is positioned between the lower shell **428** and the motor cover **444**, finger tips **494** seat in a pair of opposed strap openings **532**. This engagement of the motor cover **444** to the support strap **294** serves to provide a front support for the ventilation unit **274** above the head of the wearer.

Owing to the flexibility of both the support strap **294** and the rear nozzle assembly arch **394** and that the ventilation unit can be selectively positioned along the length of strap **294**, ventilation unit **274** is able to pivot around the rear attachment of the unit rear nozzle assembly **282**. Motor cover fingers **492** are flexible. This means the position of the ventilation unit **274** can be selectively set to be relatively close to or spaced from the front nozzle assembly **280**. The ability of the rear and front bellows **498** and **528**, respectively, to both bend and expand and contract ensures that, as the position of the ventilation unit **274** changes, the unit still is able to supply air to the rear and front nozzle assemblies **280** and **282**, respectively. Collectively, this adjustability of the ventilation unit **274** means that the unit may be positioned relative to the head of the wearer wherein it will least likely impose a strain on the wearer.

Strain on the wearer is also reduced by the fact that the center of gravity of the ventilation unit **274** is relatively close to the seventh cervical vertebra. This goal is accomplished by shaping the components such as the lower shell **428**, upper shell **430** fan **433**, motor cover **444** and grill unit **470** so that they extend downwardly from their centers. As discussed above, this shaping approximates the back of the skull, the portion of the head against which the ventilation unit is typically fitted.

Still another reason this invention minimizes strain on the wearer is that the head unit is relatively light in weight. The head unit **270**, include the head band **272**, the ventilation unit **274** the front nozzle assembly **280**, the rear nozzle assembly **284** and face frame **286** typically has a weight of less than 450 grams. In more preferred versions of the invention, this assembly has a weight of less than 400 grams.

In regard to the minimization of this strain, experiments with head mounted equipment have shown that the strain is kept to the minimum if the center of mass is located over the

22

seventh cervical vertebra. Thus a wearer of this head unit **270** is able to configure the unit so that the unit's center of mass is located as closely as possible positioned over this landmark. Again this position can be accomplished regardless of the head size of the wearer.

Regardless of the adjustment of the size of the head band **272** and the position/orientation of the ventilation unit **274** relative to the head band, the discharge opening of the front nozzle assembly **280** remains at a fixed position relative to the forehead band **288**. This means the transparent shield, which is suspended from the front nozzle assembly, remains a constant distance from the forehead band **288** and thus the face of the wearer. Therefore, the air flow discharged from the front nozzle assembly remains a constant distance away from the face of the wearer, regardless of the sizing of the head unit **270**. This means the front nozzle is positioned, regardless of head unit configuration, to ensure the discharge of air is at the appropriate position relative to the wearer's face to ensure, there is proper purging of CO₂ away from the face and delivery of relatively cool make up air.

Still another advantage with maintaining the front nozzle assembly **280** at a relatively constant position in front of the face is associated with hood/toga placement. As discussed below the hood/toga face shield **590** (FIG. **52**) is suspended from the front nozzle assembly **280**. Again since this assembly **280** is at relatively constant position relative to the face, transparent shield **590** is likewise at a constant distance from the face. This means the shield **590** can be located at a position so that regardless of head unit adjustment glare from either the light **276** or ambient light is kept to a minimum.

Similarly, regardless of the adjustment of the head unit, the rear nozzle assembly **282** remains essentially a constant distance from the neck of the wearer. This ensures that air discharged from tip **318**, regardless of head size and shape, optimally cool the neck.

Another advantage of so locating the transparent shield **590** essentially a constant distance from the face is that the shield can be sized to ensure that regardless of head size the field of view is essentially constant. In an ideal construction of the invention, no aspect of the head unit and the hood/toga is within the field of view except the transparent shield **590**. This can reduce feelings of claustrophobia an individual may developing using the system.

The support strap **294** is formed at the tail end thereof with a small downwardly directed tab **295** (FIG. **50**). This tab extends through slot **490** formed in the motor cover. The tab provides a visual indication of the extent to which the support strap **294** is extended into or retracted away from the ventilation unit **274**.

As seen in FIG. **49**, the light **276** is a self contained unit that includes an LED (not illustrated) or other light emitting element. Light **276** is pivotally mounted to a bracket **540** that is attached to forehead band **288**. Specifically, the bracket **540** includes a flat base **542**. Fasteners, (not illustrated,) hold the bracket base **542** to the face frame forehead band **288** immediately below support strap **294**. Two arms **544** extend diagonally downward from base **542**. The light is pivotally mounted to and between the free ends of the bracket arms **544**.

A support wire **546** controls the up/down angle of the light **276**. The wire extends from a small tab **548** that is slidably mounted to the rib **519** on the top of the front nozzle assembly. The tab **548** has feet (not illustrated) that sit in rib slots **521**. The feet-in-slot arrangement facilitates the friction fitting of the tab **548** along the length of the rib **519** so that the tab can be slid to a left in position.

Wire **546** extends from tab **548** through cap opening **523** to the light unit **276**. The pivotal up/down position of the light

276 is set by adjusting the position of the tab 548 along the length of the front nozzle assembly 280.

As seen in FIG. 50, a flex circuit 560 is mounted to the inner surface of the face frame chin bar 292. Flex circuit 560 supports two lower power indicator LEDs 562 and 564 and a microphone 566. While not illustrated it should be understood that layered on the flex circuit are the conductive traces that extend to the LEDs 562 and 564 and the microphone 566.

More particularly, returning to FIG. 35, it can be seen that the face frame 286 around the posts 290 and chin bar 292 has an inwardly directed lip 568. The flex circuit 560 has a main body 570 with generally rectangular shape. Three fingers 572 integral with the flex circuit main body 570 extend upwardly from the main body at longitudinally spaced apart locations along the upper side surface of the main body. The LEDs 562 and 564 are mounted to the outer surface of the two outer flex circuit fingers 572. Each LED 562 and 564 extends through a separate opening 574 formed in the face frame chin bar lip 568.

The microphone 566 is mounted to the center located flex circuit finger 572. This finger 572 wraps around so as to overlap the flex circuit main body 570. A cap (not illustrated) is fit over the chin bar 292 to cover the flex circuit. The microphone 566 extends through an opening in this cap so as to be directed to the mouth of the wearer.

A first one of the LEDs, arbitrarily LED 562, performs the function of the power monitor enunciator 234 (FIG. 22). Thus LED 564 is illuminated whenever the power monitoring circuit determines that the battery 562 is almost discharged.

The second LED, LED 564, and microphone 566 are associated with the communications unit internal to the head unit 270. The microphone 566 converts the words spoken by the wearer into electrical signals. The transceiver controller circuit 256 actuates switch 258 to place the communications system in the "mute" mode.

Also mounted to chin bar 292 are the wearer actuated switches 578, 580 and 582, seen in FIG. 51, for controlling the system. The switches 578, 580 and 582 are formed from silicon rubber and have carbon contacts. A first one of the switches, switch 578, is mounted in a first opening 584 defined by the chin bar 292. The remaining two switches 580 and 582 are mounted in a second chin bar opening 586.

Flex circuit main body 570 is disposed over the chin bar openings 584 and 586. Formed on these surfaces of the flex circuit 560 are the conductive traces against which the switch carbon contacts abut (contacts not shown.) A first one of the switches, switch 578, performs the function of switch 258. This switch 578 is actuated to take the communications system in and out of the mute mode. The remaining two switches are analogues to switches 120 and 122. Switches 580 and 582 thus are depressed to regulate the speed of the ventilation unit fan 278.

An advantage of the above placement of switches 578, 580 and 582 is that the switches are immediately in front of the wearer. This makes it relatively easy for the wearer, by moving a hand towards his/her head to actuate the switches. Thus, an individual wearing this unit 270, for most definitions of a sterile field, does not have to move his/her hand out of the field in order to actuate the switches.

FIG. 52 illustrates the transparent shield 590 attached to a hood or toga used with head unit 270. Shown as a dashed line is the position internal to the perimeter of the shield 590 around which the sterile material forming the hood or toga is secured to the shield 590. The top of the shield 590 is formed to have a tab 592. Tab 592 has a slot shaped opening 594. Opening 594 is rectangular in shape and on an axis parallel to the latitudinal, right-to-left axis of the shield 590. The open-

ing 594 further has an extension slot 595 that extends upwardly. Extension slot 595 is centered on the longitudinal, up-to-down axis of the shield 590.

Shield 590 is formed to have two circular openings 596. Each opening 596 is located adjacent a side edge of the shield 590 above the curved edge that functions as the transition edge between the side edge and the shield bottom edge. Cuts 598 extend radially from each opening 596. It is appreciated that openings 594 and 596 are located in the perimeter section of the shield 590. This is the section of the shield that is covered by the material forming the sterile hood or toga.

When the hood or toga is to be fitted to head unit 270, the shield is placed over the head unit so that the tab 524 integral with the front nozzle assembly 280 is inserted in shield opening 590. Front nozzle assembly web 525 seats in opening extension slot 595. This seating of the shield 590 over the static tab 524 and web 525 serves to align the shield with the outer components of the head unit 270 and prevent rotation of the aligned shield.

Shield 590 is then curved around the face frame 286. This flexing of the shield 590 brings each of the shield openings 594 into alignment with a separate one of the face frame pins 296. Shield openings 594 are smaller in diameter than heads 298 of the mounting pins 296. Thus, at this time the shield 590 is snap fitted over pins 296. This engagement secures the shield 590 and the associated hood or toga, to the head unit.

In this version of the invention, there is spacing of at least 3 cm between the topmost attachment of the shield 590 to tab 524 and where the shield is attached to the two laterally spaced apart pins 296. As a consequence of this arrangement, when the shield is fitted to the head unit 270, the radius of curvature of the shield varies along the top to bottom longitudinal axis. More particularly at the top of the shield, adjacent the tab, there is a relatively wide diameter radius of curvature. Between pins 296 the shield has a smaller diameter of curvature, a more pronounced curvature.

An advantage of this construction is that near eye level the less curved, relatively flat, shield profile minimizes the amount glare. This arrangement also serves to assist in the shield's suspension of the material forming the hood/toga away from the forehead and top of the wearer's head. This feature provides a relatively large transparent shield-hood free space around the top of the head. This reduces the effort required to fit auxiliary equipment, such as a heads up display, a camera, other communication devices or lights around the wearer's head.

Another advantage of this configuration of this invention is that openings 594 and 596 serve as the means integral with the shield 590 for holding the shield to the head unit 270. This arrangement eliminates the need to provide snap heads, magnets or hook-in-fabric fastening strips to the hood/toga on the shield in order to facilitate the attachment of the shield to the head unit. The elimination of these fastening members results in a like elimination of the costs associated with providing the shield with these components.

VII. Alternative Light, Communications and Fan Unit

FIG. 53 is a diagrammatic illustration of how a number of components of the personal protection system 10 of this invention are, in some versions of the invention, contained in a single housing 610. Housing 610 is configured to be worn someplace on the individual. For example, the housing 610 may include a clip (not illustrated) so it can be attached to an article of clothing such as a belt. The housing 610 may alternatively include a strap (not illustrated) so it can be strapped to the individual.

Internal to the housing 610 is the power supply 70. Also integral with the housing is the transceiver 242. A cable 612

25

that leads to head of the individual includes the conductors that are connected to the microphone **238** and speaker **240**. In these and other versions of the invention, the microphone and speaker may be built into a head set separate from the structure used to suspend the hood. Also disposed inside housing **610** is a fan **52a**. The majority of the airflow output by the fan is discharged through a flexible tube **614**. Tube **614** is connected to the output vents in the body support structure from which the air should be discharged.

A light generating unit **616** is also contained housing **610**. The light generating **616** unit may contain an LED or an incandescent bulb such as a halogen bulb. A fiber optic cable **618** extends from the light generating unit **616**. The distal end of the fiber optic cable is attached to the light emitting head **620** attached to the body support structure.

In this version of the invention, the outlet flow from the fan **52a** is discharged from two ports, (not shown). The proximal end of tube **614** is connected to one of the ports. The second port leads to a duct **622** in the housing. Duct **622** is located between the face of the sub housing **302** in which the light generating unit **616** that would be closest to the wearer of the system **10** and the adjacent structural wall of the housing **610**. Thus, the system is actuated fan **52a** continually blows new make-up air into duct **298**. The air is discharged from exhaust ports **624** formed in the side of the housing **610**. This constant supply of this air minimizes the extent to which the heat generated by the light generating unit **616** convectively warms the housing **610** and the adjacent portion of the body of the wearer.

An advantage of this version of the invention is that the majority of the weight of the active components of the personal protection system **10** are suspended from the waist or other body part of the user where the presence of such weight does not induce significant appreciable physical stress.

VIII. Alternative Features

Body-worn support structures for suspending the hood other than the illustrated and described helmet may be employed in this invention. One possible structure is a shoulder mounted frame. This frame contains structural members for supporting the hood. This fan or light generating unit may be directly mounted to this support structure. In versions of the invention where both components are so mounted to the support structure, a duct is present to circulate a fraction of the air discharged by the fan around the light generating unit. Alternative embodiments of this version of the support structure of this invention may simply have ducts for receiving the air and ports through which the air is discharged and a light emitting head for emitting the light. In these versions of the invention the waist mounted unit contains the fan and the light generating unit.

In some versions of the invention, the body support structure includes a vest like garment worn about the trunk of the wearer. Integral with this garment are one more supports from which the hood is suspended.

Also, in some versions of the invention, the support unit may include an outwardly directed speaker. For example, this speaker could be mounted to flex circuit **560**. In these versions of the invention, there is also an amplifier capable of amplifying the signals produced by microphone **566**. These signals are broadcast by this speaker through the hood/toga into the surrounding environment. This arrangement eliminates the need to provide RF signal transceivers.

It may also be desirable to provide the transparent shield of the hood/toga with at least one section that transmits sound. (Generally the material forming the transparent shield absorbs or reflects sound.) Thus, the transparent shield could be formed an opening that is generally aligned with the mouth

26

of the wearer. This opening is covered with a section of the sterile material from which the rest of the hood/toga is formed. This construction can eliminate the need to provide any assembly for broadcasting or amplifying the speech of the wearer.

Alternatively the transparent shield opening may be covered with material that absorbs and retransmits sound waves. Electrometric materials such as a silicon rubber may perform this function.

It should likewise be appreciated other duct assemblies may be provided to direct air from the ventilation fan to the light generating unit. For example, there may be a duct within either the front or rear nozzle assembly that leads directly to the light source. This duct extends to a conduit, which may be flexible, that extends to the light source. In some versions of the invention, this conduit opens into the inside of the housing of the light source. Thus, the air passes directly over the heat generating, light emitting elements or heat sink elements internal to the light source housing.

Alternatively, in some versions of this invention, the light source has its own ventilation fan. This arrangement may be useful if it is necessary to flow large volumes of air over the light source.

In either of the above versions of the invention, the light source may be formed with a conduit through which the air introduced into the source is exhausted. This conduit has an exhaust port that opens away from the wearer.

It may also be desirable to position a temperature sensitive transducer adjacent the heat generating components of the light source. The signal output by this sensor can be used to regulate the light source and/or the fan that provides the air for cooling the light. Thus when this sensor indicates the temperature adjacent the light source is rising to uncomfortable levels, the current regulator **230** could respond by reducing the power supplied to the light. When this condition is detected, alternatively, microcontroller **118** could step up the speed of the fan so as to increase the air flow over the light source.

It should be appreciated that there are reasons other than wearer comfort for so controlling the temperature of the light source and the space surrounding the source. This excessive heating of the light source can appreciably diminish its useful life. In some instances, the excessive heating of the source can cause its failure. Also, this heat, if not exhausted, could potentially warm the user to the point at which the skin blisters or is burned.

In some versions of the invention a heat pipe formed from thermally conductive material extends from the light source. This heat pipe may extend to a duct that extends from the fan.

An anti glare hood may be fitted over the light emitting head so as to extend between the head and the inner surface of the transparent shield. The inner surface of this hood is formed from light reflective or absorbing material. This arrangement reduces, if not eliminates, the amount of light emitted by the head that is reflected by the inner surface of the transparent shield back to the wearer as glare.

This hood may be formed from rigid or flexible material. One advantage of employing flexible material is that it can ensure the hood abuts the inner surface of the transparent shield when the shield is fitted to the helmet or head unit.

Some light systems may also be configured to provide the wearer with short bursts of high intensity light. This light is provided in response to depression of a specific control switch. The light burst may be provided in situations in which a very large amount of light is required. Only a burst of light for a period between 1 to 10 minutes is provided. Only the burst is provided so as to minimize the possibility this high

27

driving of the light source results in excessive heat being output or the source or the source being excessively operated to the level at which it may burn out.

Devices other than the bellows may be employed as the adjustable conduits that connect the ventilation unit 274 to the front and rear nozzle assemblies 280 and 284, respectively. For example, telescoping tubes and/or tubes with flexible joints may be employed as these conduits.

Further, there is no requirement that in all versions of the invention two spaced apart support members, support strap 294 and arch 394 both be provided to suspend the ventilation unit 274 above the head band 272. In some versions of the invention, a single support member or support post may be all that is required.

Also, in not all versions of the invention may it be necessary to attach the front ventilation unit 280 to the head band 272. Thus, in some versions of the invention the adjustable conduit that extends from the ventilation unit 274 to the front nozzle assembly 280 provides support for suspending the front nozzle assembly in a specific position relative to the head band.

Further, there is no requirement that the all versions of the invention include both the front and rear nozzle assemblies 280 and 282. Clearly most units will include the front nozzle assembly.

Thus it should be clear that the foregoing description is directed to specific embodiments of the invention. Therefore, it is an object of the appended claims to cover all such modifications and variations that come within the true spirit and scope of this invention.

What is claimed is:

1. A personal protection system comprising:

a helmet to be worn over the head of a wearer, said helmet including a head band that is disposed above the face of the wearer;

a hood disposed over said helmet, said hood having a transparent face shield that is forward of said head band;

a fastening assembly integral with at least one of said helmet or said hood for releasably holding said hood, including said face shield, over said helmet;

a ventilation assembly integral with said helmet, the ventilation assembly having a fan and a front nozzle that is connected to said fan to receive air output by said fan, said front nozzle having an opening through which the air is discharged that is located forward of the head band so as to be in front of the face of the wearer; and

a light assembly including a light source and a light emitting head, said light assembly being mounted to said helmet and positioned to emit light through said face shield and being located below the front nozzle opening so that air discharged through the front nozzle opening flows over said light assembly.

2. The personal protection system of claim 1, wherein said ventilation assembly further includes: a shell in which said fan is disposed, said shell being attached to said helmet so to be able to move both angularly and linearly relative to said front nozzle; and a front conduit that extends between said shell and said front nozzle so that, when the position of said shell relative to said front nozzle is adjusted, said front conduit maintains a connection between said shell and said front nozzle.

3. The personal protection system of claim 1, wherein said ventilation assembly further includes:

a rear nozzle with an outlet opening, said rear nozzle being located on said helmet opposite said front nozzle;

a shell in which said fan is disposed, wherein said shell is moveable relative to said rear nozzle; and

28

a rear conduit that extends between said shell and a rear nozzle, said rear conduit being adjustable in at least one of length or angle so that, when the position of said shell relative to said rear nozzle is adjusted, said rear nozzle maintains a connection between said shell.

4. The personal protection system of claim 1, wherein said ventilation assembly further includes:

a rear nozzle with an outlet opening, said rear nozzle being located on said helmet opposite said front nozzle; and

a front conduit extends between said fan and said front nozzle and a rear conduit extends between said fan and said rear nozzle, wherein at least one of said front conduit or said rear conduit is a bellows.

5. The personal protection system of claim 1, wherein said fastening assembly includes at least one fastening member attached to said head band for suspending said hood over said helmet so that said hood face shield is disposed forward of the head band.

6. The personal protection system of claim 1, wherein said light assembly is pivotally mounted to said helmet and further including a control arm connected to said light assembly for pivoting said light assembly.

7. The personal protection system of claim 1, wherein:

said helmet includes a chin guard positioned to extend forward from the face of the wearer; and

said fastening assembly includes at least one said fastening member attached to said chin guard for suspending a hood over said head band so that said hood face shield is disposed forward of said chin guard.

8. A personal protection system comprising:

a helmet to be worn over the head of a wearer, said helmet including a head band that is disposed above the face of the wearer;

a hood disposed over said helmet, said hood having a transparent face shield that is forward of said head band;

a fastening assembly integral with at least one of said helmet or said hood for releasably holding said hood, including said face shield, over said helmet;

a ventilation assembly integral with said helmet, the ventilation assembly having a fan and a front nozzle that is connected to said fan to receive air output by said fan, said front nozzle having an opening through which the air is discharged that is located forward of the head band so as to be in front of the face of the wearer;

a light assembly including a light source and a light emitting head, said light assembly being pivotally mounted to said helmet and positioned to emit light through said face shield and being located below the front nozzle opening so that air discharged through the front nozzle opening flows over said light assembly; and

a control arm connected to said light assembly for pivoting said light assembly.

9. The personal protection system of claim 8, wherein:

said helmet includes a shell in which said fan is mounted; and

said control arm is moveably connected to said shell; and a cable connects said lever arm to said light source.

10. The personal protection system of claim 8, wherein:

said ventilation assembly further includes a shell in which said fan is disposed, said shell being attached to said helmet so to be able to move both angularly and linearly relative to said front nozzle; and

a front conduit extends between said shell and said front nozzle so that, when the position of said shell relative to said front nozzle is adjusted, said front conduit maintains a connection between said shell and said front nozzle.

11. The personal protection system of claim 8, wherein said ventilation assembly further includes:

- a rear nozzle with an outlet opening, said rear nozzle being located on said helmet opposite said front nozzle;
- a shell in which said fan is disposed, wherein said shell is moveable relative to said rear nozzle; and
- a rear conduit that extends between said shell and a rear nozzle, said rear conduit being adjustable in at least one of length or angle so that, when the position of said shell relative to said rear nozzle is adjusted, said rear nozzle maintains a connection between said shell.

12. The personal protection system of claim 8, wherein said light assembly is pivotally mounted to said head band.

13. The personal protection system of claim 8, wherein said fastening assembly includes at least one fastening member attached to said front nozzle for suspending a hood over said head band, said ventilation assembly and said front nozzle so that said face shield integral with said hood is disposed forward of the head band front section.

- 14. The personal protection system of claim 8, wherein: said helmet includes a chin guard positioned to extend forward from the face of the wearer; and said fastening assembly includes at least one fastening member attached to said chin guard for suspending a hood over said head band so that said hood face shield is disposed forward of said chin guard.

15. The personal protection system of claim 14, wherein said chin guard further includes a microphone.

16. A personal protection system comprising:

- a head band shaped to be worn around the head of a wearer, said head band having a front section worn above the face of the wearer and a rear section opposite the front section;
- a front nozzle attached to said head band so as to be located forward of said head band front section, said front nozzle having an opening;
- a ventilation assembly located above said head band, said ventilation assembly including: a shell; and a fan disposed in said shell for drawing air into said shell;
- a first support that extends upwardly from said head band to said ventilation assembly shell for supporting said shell above the head of the wearer, said first support being angularly moveable relative to said head band;
- a fastening assembly integral with said ventilation unit shell and said first support for holding said shell to said first support at a plurality of different locations along

said first support so that the position of said shell relative to said front nozzle can be adjusted;

- a front conduit that extends between said shell and said front nozzle, said front conduit being adjustable in at least one of length or angle so that, when the position of said shell relative to said front nozzle is adjusted, said front conduit maintains a connection between said shell and said front nozzle;
- a light assembly including a light source and a light emitting head, said light assembly being mounted to said head band and positioned to emit light through said face shield and being located below said front nozzle opening so that air discharged through said front nozzle opening flows over said light assembly;
- a rear nozzle located adjacent said head band rear section that is connected to said shell to receive and discharge air discharged by said fan; and
- at least one fastening member attached to said head band for suspending a hood over said head band, said ventilation assembly and nozzles so that a face shield integral with said hood is disposed forward of said head band front section.

17. The personal protection system of claim 16, wherein: said shell can be adjustably positioned relative to said rear nozzle; and

- a rear conduit extends between said shell and said rear nozzle, said rear conduit being adjustable in at least one of length or angle so that, when the position of said shell relative to said rear nozzle is adjusted, said rear nozzle maintains a connection between said shell and said rear nozzle.

18. The personal protection system of claim 16, wherein: a rear conduit extends between said fan and said rear nozzle; and

- at least one of said front conduit or said rear conduit is a bellows.

19. The personal protection system of claim 16, wherein said first support is formed as an integral extension of said head band.

20. The personal protection system of claim 16, wherein said light source is configured to emit light of varying intensity, the intensity being controlled by a light control circuit that selectively applies an energization signal to said light source to control both on/off state of said light source and the intensity of the light.

* * * * *